This is a reproduction of a library book that was digitized by Google as part of an ongoing effort to preserve the information in books and make it universally accessible.

Google™ books

<http://books.google.com>



NYPL RESEARCH LIBRARIES



3 3433 02324704 6



Digitized by Google

T. F.

Sleep

Clue.

Slee

T-

1922
1932

1111100.

The Radio Experimenter's Hand Book

*A Book to Answer the Practical Problems of
Beginners and Advanced Students of
Radio Experimental Work*

By

M. B. SLEEPER

Editor of the Experimental Section, Proc. I. R. E., Radio
Editor of Everyday Engineering Magazine, Author
of Radio Hook-ups, Design Data for
Radio Transmitting and Receiving
Apparatus, etc.

LIBRARY OF THE
RADIO SOCIETY OF AMERICA
1111 15th St. N.W.
WASHINGTON, D. C.

15

PUBLISHED BY

THE DE FOREST RADIO TEL. & TEL. CO.

New York City

1920

M.S.V.

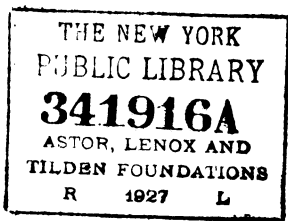

COPYRIGHT 1920 BY
THE DE FOREST RADIO TELEPHONE AND TELEGRAPH COMPANY

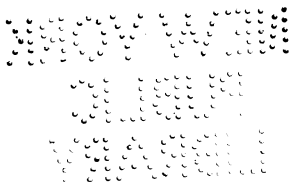

PREFACE

· THROUGHOUT the work of preparing this book, one purpose was kept in the mind of the author—to answer the practical problems which confront those who are starting to feel the call of the most fascinating work to which boy or man can turn to for unending amusement or relaxation.

From the early days when the entire field of radio could be covered in a small book, the art has advanced until the literature available and the apparatus offered for sale by various manufacturers confuses the beginner to discouragement.

Consequently, all theoretical and mathematical discussions have been omitted, and the apparatus considered limited to simple and practical instruments. If this book will help experimenters on their road to familiarity with radio circuits and equipment, its purpose will be realized.

Acknowledgment is made of the assistance of Mr. Robert Smith, radio draughtsman, who prepared the illustrations.

THE AUTHOR.

27 X 3
January 28, 1920.

CONTENTS

CHAPTER I—WHAT IS THE USE OF HAVING A RADIO STATION?

A review of the experimenters' activities, with some answers to conscientious objectors and landlords. *Page 7*

CHAPTER II—WHAT MAKES THE WIRELESS WORK?

Explaining in simple terms the action of a radio transmitter and receiver. *Page 11*

CHAPTER III—APPARATUS USED IN SIMPLE DAMPED WAVE TRANSMITTING SETS

On the use and construction of the various instruments and the necessary qualities of purchased apparatus. *Page 21*

CHAPTER IV—SETTING UP AND OPERATING A DAMPED WAVE TRANSMITTER

Confusing questions which confront the experimenter who is putting up a transmitter are answered. *Page 34*

CHAPTER V—APPARATUS USED IN SIMPLE DAMPED WAVE RECEIVERS

Two-slide tuners, detectors, buzzer tests, honeycomb coil receivers, and other instruments are discussed. *Page 40*

CHAPTER VI—SETTING UP AND OPERATING A SIMPLE DAMPED WAVE RECEIVER

Describing the methods of handling the apparatus, with notes on the actions which take place. *Page 50*

CHAPTER VII—RADIO ANTENNAS AND GROUNDS

Various types of antennas and loops, lightning switches and grounds are taken up in this chapter *Page 54*

CHAPTER VIII—ADVANCED DAMPED WAVE RECEIVING APPARATUS

Loose coupled honeycomb circuits are described, and a wavelength table is given to facilitate the selection of coils for various wavelengths. *Page 61*

CHAPTER IX—HOW DOES AN AUDION WORK?

The mysteries of the Audion are cleared away in this chapter which shows how and why it operates. *Page 70*

CHAPTER X—DAMPED WAVE AUDION RECEIVING APPARATUS

This chapter describes the instruments used in receiving with an audion detector. *Page 77*

CHAPTER XI—ADVANCED DAMPED WAVE AUDION RECEIVING APPARATUS

x Giving the details of grid leaks, bridging condensers, series-parallel condenser switches, regenerative sets. *Page 83*

CHAPTER XII—WHAT IS AN UNDAMPED WAVE?

The answer to this question and to many others on the transmission and reception of undamped waves are contained in this chapter. *Page 92*

CHAPTER XIII—UNDAMPED WAVE TELEGRAPH AND TELEPHONE TRANSMITTERS

The simple and most suitable circuits for vacuum tube transmitters, both telephone and telegraph. *Page 101*

CHAPTER XIV—UNDAMPED WAVE RECEIVERS

High-powered undamped transmitters can be heard with the instruments and circuits of which details are given. A list of foreign and American stations is given. *Page 112*

CHAPTER XV—THE AUDION AMPLIFIER

y Transformer coupled amplifiers, the most satisfactory type, of one and two stages, are taken up, with the details of their use *Page 117*

CHAPTER XVI—RADIO RULES AND REGULATIONS

Giving operating instructions, abbreviations, stations sending press and weather reports. *Page 123*

Radio Experimenter's Hand Book

CHAPTER I

WHAT IS THE USE OF HAVING A RADIO STATION?

Many a would-be experimenter has been discouraged in his plans for a radio station by such ideas, advanced by elder people, as, "You will be tired of it as soon as you get it," "Why, a wireless set costs a small fortune," or "No, sir, this house isn't going to have anything on it to attract lightning."

A wireless station is the one indoor occupation that never grows old or tiresome. Rainy days or winter evenings are no misfortune in the home where the wireless is ticking out dots and dashes—NAH, perhaps, telling the battleships what to do or where to go, Arlington regularly following the clock pendulum as it sends time signals to the world, or possibly Nauen, in far-away Europe, carefully disguising by secret code a new plan of intrigue.

Radio telephony is coming rapidly into wide experimental and commercial use. It is the most astonishing experience, when, through the signals of

8 *Radio Experimenter's Hand Book*

some telegraph station, comes a "Hello, Boston, this is New York calling," and, a moment later, "New York, I can hear you perfectly; go ahead." Again, it may be the de Forest station, now familiar to radio men, "This is the de Forest wireless telephone at Highbridge. We are going to play 'When the M-M-Moon Shines over the C-C-Cow Shed.' Just a minute," and, after a short delay, the music is heard, sharp and clear, even a better reproduction than at the phonograph itself.

Sometimes the enterprising experimenter puts an extension telephone on his radio set, then, calling someone on the telephone, holds the wireless 'phone to the transmitter, and the music is heard over the land line by someone who does not believe in radio, or is not fortunate in owning a station.

There is no end to the things that can be done, no greater incentive to ingenious thinking, no exhausting the possibilities offered by a simple wireless outfit.

The general advice, given by fellow experimenters, who have had radio sets for a long time, or the ideas found in magazines may give some misconception as to what is required in the way of equipment. The result may be an apparently prohibitive cost. Actually, a simple receiving set which will copy commercial stations from a distance of 500 miles or more is quite small. If all the instruments are bought, the cost is under fifteen dollars. When made by the experimenter himself, the materials will not come to ten dollars.

The Use of Having a Radio Station 9

It is always advisable to put up a receiving station first. Only a few instruments are required, they are easy to handle, and require no skill to operate. Moreover, a receiving set needs no license, while a transmitting station must have a license, and the owner an operator's license. By the time a little experience has been gained at receiving, the experimenter will be ready to take an examination, as explained later on, and will know how to handle a sending set.

Before the War, it was ordinarily considered that high masts and many wires were needed. Since the development of that period, single wire antennas have been used almost exclusively by experimenters, while low supports, such as houses and trees, have replaced the high masts. Accordingly, the total antenna cost is not over three dollars.

There is no reason for buying expensive or elaborate instruments at the start. The more equipment, the greater the difficulty in operating it, and the larger the liability of failure due to the inexperience of the operator. There is more pleasure in connecting up a few simple instruments and hearing signals than worrying with much apparatus and no results.

Experimenters who are really interested in "what it does and how it does it" find the most satisfaction in mastering the details and operation of each instrument as they add it to their stations. That is the way of the logical mind, and, under cover of providing a real indoor sport, radio work offers

10 *Radio Experimenter's Hand Book*

to the younger minds a tremendously valuable developer of logical and analytical thinking more effective than school book methods, since this object is accomplished by real entertainment.

The landlord who objects to the erection of an antenna, or the mother who does not want a single little radio room upset, is really taking a narrow-minded view of the matter, not realizing that they are depriving the would-be experimenter of an actually educational advantage.

As for the danger from lightning, no one could ask for better protection against it than is afforded by an antenna properly grounded in the manner described in Chapter VII. Except in districts where thunderstorms are exceptionally severe, a single wire seldom needs a heavy ground and lightning switch. Some experimenters simply drop the antenna lead to the ground, so that it is clear of the house. Lightning danger is an absurd objection to a radio station.

CHAPTER II

WHAT MAKES THE WIRELESS WORK

Did you ever look inside a piano? Have you ever plucked the wires? Then listened to the sound, gradually dying away? Your first experience was probably at a time when you weren't much concerned with wireless, or it was before there was a wireless, anyway.

Really, though, you had a little wireless in the piano. Didn't the taut wire send a singing message to your ear? It did, all right, but how did it happen? Vibration did it.

Think, for a moment, of the clock pendulum. Ordinarily, gravity keeps it hanging straight down, but, if you draw the weight to one side and let go, it will swing back and forth. If you could time it, you would find that it takes as long for the first, long swing as for the short ones, when it has nearly stopped. The time it takes to go from straight up and down, out to the side, and back again is always the same. When, however, you change its length, the time required for the swing will be different.

The piano wire acts in the same way. The tension ordinarily keeps the wire straight. When it is plucked, it vibrates as the pendulum does, back

12 *Radio Experimenter's Hand Book*

and forth. With the wire, as with the pendulum, it will be found that the time required for each vibration is the same when it has nearly stopped vibrating or when it is first struck. Changing the tension or length of the wire changes the rate of the vibrations or the *natural period*, as it is called.

When you stop to think of it, striking the piano wire causes it to vibrate, the wire sets up air vibrations which travel to the ear, and one of the nerves in your ear, whichever is tuned to that particular period, is vibrated by the air waves. Finally, the response of the ear nerve is detected by the brain, and you say that you hear the piano wire sing.

As you will see later, this piano wireless closely resembles a radio set. A wireless transmitter is really a generator of electrical vibration equivalent to the wire. The electrical vibrations or waves are radiated from the sending antenna, picked up at the tuned receiving station, and made audible by telephone receivers.

Have you ever watched a piano tuner adjust the wires to their proper tones? Did you see how he used his tuning fork? When he struck the fork it made a singing sound at a certain pitch. If he held it near a wire adjusted to the same pitch or frequency, the wire sang too, yet wires of other frequencies did not sing. That shows the necessity of tuning the receiver to the frequency of the transmitter, whether it is a tuning fork transmitting to a piano wire, or a wireless set sending to a receiving set.

You can hear the piano wire singing whether you stand in front, behind, or at the side of the piano. The wire sends out air vibrations in all directions. So does the wireless transmitter send out electrical vibrations all around the station, north, east, south and west.

Probably you have heard or read about wavelength. Sounds rather mysterious, but the meaning is simple. Imagine that you can throw a stone from here to the moon, and that it travels a foot a second all the way. If you throw a stone every second, the first will travel one foot before the next one starts, and so on. You will have a string of stones a foot apart traveling toward the moon.

We might say that the wavelength of these stones is one foot, since that is the distance between them.

In wireless work, we throw out electrical waves which travel at the enormous speed of 175,000 miles a second, or, using the metric system, 300,000,000 meters per second. If the wireless transmitter is tuned to a frequency of 1,000 per second, the waves will be 300,000 meters apart, or the wavelength will be 300,000 meters. To put it differently, a frequency of 1,000,000 gives a wavelength of 300 meters.

Frequencies of 15 to 15,000 are spoken of as audio frequencies, because vibrations, such as from a wire, can be heard, while those from 15,000 to 1,500,000 and higher are called radio frequencies. They are most commonly used in wireless work, yet they cannot be heard.

14 *Radio Experimenter's Hand Book*

A simple mechanical vibration as of a wire or pendulum consists of a movement from the normal position out to the side, back to normal, out to the other side, and back to normal. This is a complete cycle of operations.

An electrical vibration or cycle is a little different, for starting at no current, the current flowing

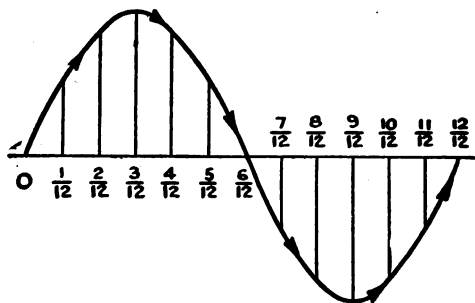

Fig. 1.—A Complete Cycle of an Alternating Current.

in one direction rises to a certain value, drops off to nothing, rises again, flowing in the other direction, and falls off to nothing. Electric current while it acts in this manner is called alternating current. A picture of a current alternating at a frequency of one complete cycle per second would look like Fig. 1. At the beginning, there is no current. In one-twelfth of a second it rises to a value indicated by the first line. By the end of three-twelfths of a second, the full current is flow-

ing. Then it drops back to zero, and rises and falls again, but flows the other way through the circuit.

Now, what makes the current behave in this manner? Current from a storage battery or dry cell flows steadily. That is direct current. Alternating or oscillating current may be obtained from a generator. Perhaps where you live your lights

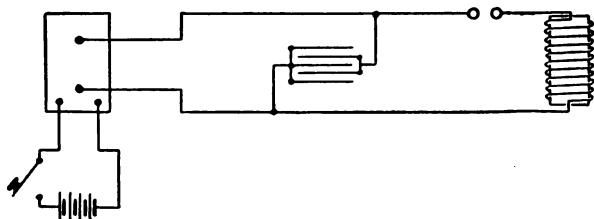

Fig. 2.—Connections for a Spark Coil, Condenser, Spark Gap and Inductance.

work on A. C. Spark coils are also used to produce A. C. current.

Suppose you have a spark coil, a condenser, spark gap, and inductance. These instruments will be described later—just keep the names in mind. The spark coil has two windings, called primary and secondary. A battery and interrupter are connected to the primary coil. Due to the interrupter and the construction of the secondary coil, a high voltage alternating current is set up across the ends of the secondary winding, though the battery may

16 *Radio Experimenter's Hand Book*

have only six volts. You will see, when you close the primary circuit, that a long spark jumps across the secondary terminals.

A condenser is made up of tin foil sheets with glass between them. No current can flow through the glass. Therefore, if a condenser is connected across the spark coil, Fig. 2, the alternating current, flowing in one direction, will simply pile up in the condenser until it can hold no more. Then

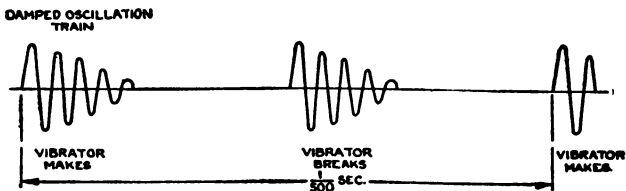

Fig. 3.—Showing the Groups of Damped Oscillations.

it discharges like a rubber balloon blown too tight. The resistance of the secondary is greater than that of the air space in the spark gap, and it jumps across, flows through the coil of wire or inductance, and piles up on the other side of the condenser. Back and forth it rushes, traveling with the speed of light, but gradually diminishing in strength, until it stops.

Every time the vibrator makes or breaks the current, one of these trains of alternating current or oscillations is started. Since they gradually die out, they are called damped oscillations. Fig. 3

shows how the current oscillates and how the oscillations die out until another movement of the vibrator starts another train.

You will see that the current changes at a tremendous rate, so that several oscillations take place during a single movement of the vibrator. The rate of these oscillations or the wavelength depends

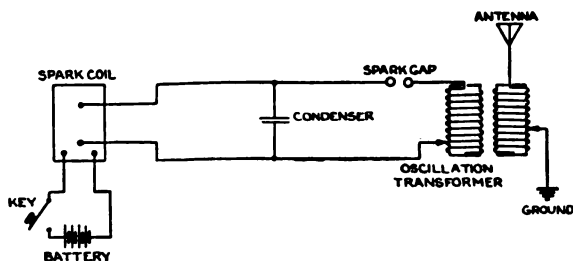

Fig. 4.—A Diagram for a Complete Transmitting Set.

upon the size of the condenser and inductance in the circuit, just as the weight and length of the pendulum affect the rate at which it swings.

Increasing the condenser or the inductance increases the wavelength. Reducing either of them reduces the wavelength.

In actual practice, the transmitter is connected to the antenna and ground as in Fig. 4. The oscillations, taking place in the transmitter, charge the antenna and ground, which, in themselves, act as a condenser, for the antenna constitutes one tin foil

18 *Radio Experimenter's Hand Book*

plate, the ground the other, and the air takes the place of a glass plate. Since there is inductance in the antenna and ground wires, there is really another oscillating circuit, from which electrical waves are radiated. As it is necessary in all electrical circuits to have a complete circuit, the air

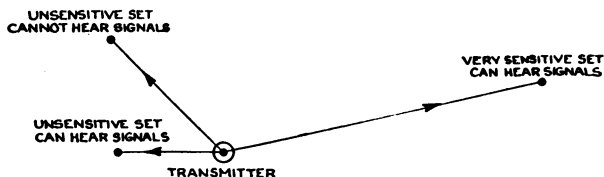

Fig. 5.—The Ranges Depend Upon the Power of the Transmitter and the Sensitiveness of the Receiver.

acts as one side of the line, and the ground as the other.

The waves are sent out in all directions from the antenna, and any station fitted with receiving apparatus can pick up the messages. Of course, if the transmitter is of low power, perhaps it has only a small spark coil, the waves will die out before they have gone many miles. On the other hand, a receiving set that does not have sensitive instruments requires stronger waves to produce signals in the telephones, while a sensitive receiver will pick up the weakest waves.

It should be mentioned here that some companies advertise transmitting and receiving apparatus as being able to send or receive a certain number of

miles. This may be misleading, as will be seen from the previous paragraph, for the range length of a transmitter depends upon the type of receiver used; the range of a receiver depends upon the power of the transmitter. Reputable companies rate the receiving distance of a set by referring to one special station, such as the Arlington time signal trans-

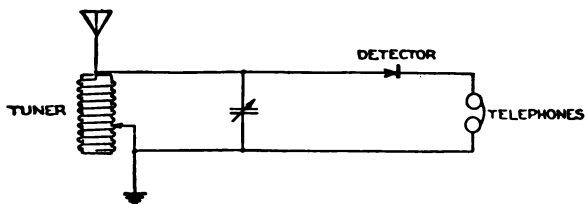

Fig. 6.—Wiring Diagram for a One-Slide Tuner and a Crystal Detector.

mitter. Transmitting distances cannot be estimated accurately.

You will remember about the piano wire and the tuning fork. A receiving set will not respond to electrical waves unless it is tuned to the wavelength of the transmitter. Therefore, it is necessary to have adjustable inductances and condensers in order to tune to the incoming signals.

Fig. 6 shows the receiving antenna and ground connected to a tuning inductance and variable condenser. Of course, frequencies of several hundred thousand cycles will not produce sounds in the

20 *Radio Experimenter's Hand Book*

telephones, because they are beyond audibility. It will be remembered, however, that the high frequency oscillations come in groups, as shown at Fig. 3. If a device such as a detector is put in the receiving circuit which will allow the current to flow in only one direction, the current through the detector will be as in Fig. 7—a series of impulses in

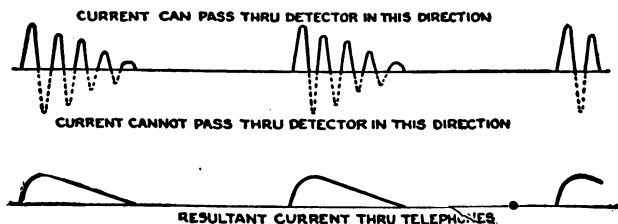

Fig. 7.—This illustrates the Rectifying Action of a Crystal Detector by Means of Which Audible Signals are Produced.

one direction. The current through the telephones is smoothed out, however, into single impulses of a frequency corresponding to the speed of the vibrator on the spark coil. Thus the diaphragm of the telephone is drawn down at an audible frequency rate.

In this way, you see, damped electrical oscillations pass between the stations at inaudible frequencies, yet, because the waves travel in groups, the group frequency is used to produce audible signals.

CHAPTER III

APPARATUS USED IN SIMPLE DAMPED WAVE TRANSMITTING SETS

Although, as was explained in Chapter I, it is customary to put up a receiving station first, sending instruments will be discussed before receivers to make more clear the action and operation of the equipment. In this chapter, the instruments used for transmitting will be described and, in the following one, their action and use will be taken up.

The Spark Coil.—If you have ever owned a little shocking coil, or have had anything to do with automobiles, you probably know what a spark coil is. In a few words, a spark coil is a producer of high voltage current such that the electricity will jump across a short space between two wires. A coil of this sort is shown in Fig. 8, and the connections of the complete instrument in Fig. 9. In the first place, there is a soft iron core, around which is placed a fiber or bakelite tube for insulation. Over this tube comes a primary winding of heavy wire, usually in two layers. Next, another insulating tube and the secondary coil. This has many turns of very fine wire.

Mounted at the end of the iron core is a vibrator. Fig. 9 shows that when the battery circuit is closed,

22 *Radio Experimenter's Hand Book*

current flows across the vibrator contacts and through the primary winding. This magnetizes the core, and the iron piece on the vibrator spring is drawn forward. But when this happens, the contact points are separated and, with the electric circuit opened, the core is no longer magnetized. The

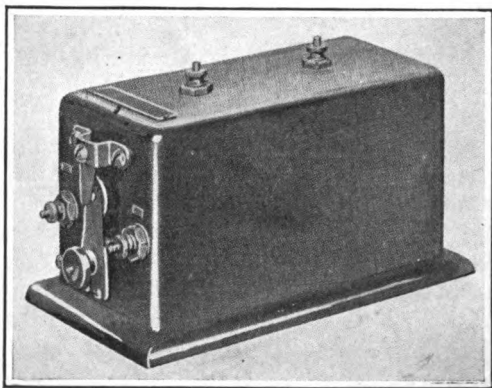

Fig. 8.—A Spark Coil for Small Transmitters.

moment the iron piece on the vibrator is released, the spring flies back, closes the circuit, and the operation just described is repeated. As long as the switch is closed, the spring vibrates back and forth.

Each time the current flows through the primary, magnetic lines of force spring up around the coil, as shown in Fig. 10, and fall away when the vibrator opens the circuit. When a wire loop is held

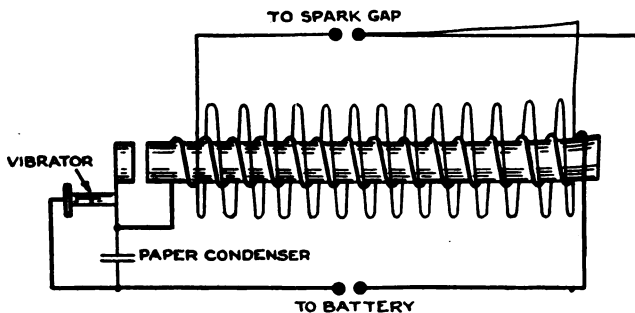

Fig. 9.—Connections for the Vibrator of a Spark Coil.

in a changing magnetic field, a current is induced in it. Accordingly, the rising and falling magnetic lines cut the turns of the secondary coil and a cur-

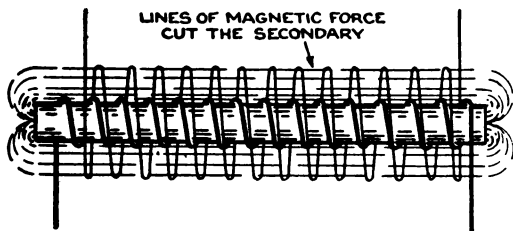

Fig. 10.—Changing Lines of Force Set Up by the Primary Induce Currents in the Secondary.

rent is set up in it. It has been found that the voltage in the secondary is increased if there are more turns than in the primary coil. Thus, if the secondary has 100 times as many turns as the pri-

24 *Radio Experimenter's Hand Book*

mary, and a 6-volt dry battery is connected to the primary, there will be 600 volts in the secondary.

Of course, the amperage is reduced in the secondary, but the voltage is stepped up until it will jump one inch or more. Spark coils with several miles of wire in the secondary give sparks two or three feet long. However, for radio work, a long, thin spark is not as good as a short, thick one. The flame should be heavy and blue-white looking, and hot enough to light a piece of paper. This is an important point to remember in buying a coil. Also, a cheap coil that is advertised to give a long spark is usually not as good as a high grade type which gives a shorter spark.

As for building a coil at home, it can be done, but the results seldom justify the work, and the materials actually cost as much as the finished instrument. This is one case where it is better to buy than construct.

Batteries.—Some source of current is, of course, necessary to run the spark coil. Many experimenters have collected discarded dry cells from automobile garages and found them good enough for lights and bells. They seldom have enough "pep" for spark coils, although it may be possible, by connecting them in series parallel, to do the work.

Fig. 11 shows three different ways to wire up cells. The series method is used for new batteries when only a few can be bought at a time. If each cell gives $1\frac{1}{2}$ volts and 15 amperes, several in series will give a voltage equal to the individual

voltage multiplied by the number of cells, while the total amperage will be equal only to that of a single cell.

The reverse is true when they are in parallel or multiple, as it is sometimes called. That is, the

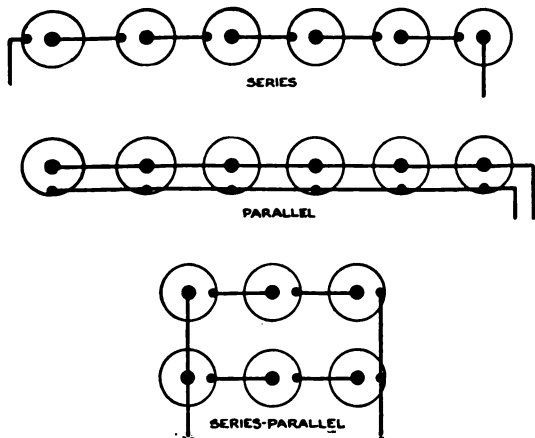

Fig. 11.—Batteries Connected in Different Ways for Various Purposes.

total voltage is equal to that of one cell, while the total amperage delivered is the product of the separate amperage times the number of cells.

Now, if you connect a spark coil which takes 10 amperes to 5 batteries in series, 10 amperes will be drawn from each cell. On the other hand, if it is wired with 5 batteries in parallel, only 2 amperes

26 *Radio Experimenter's Hand Book*

will be taken from each cell. Since it is using a large amperage from each battery that runs them down, it is advisable to have them in parallel. However, the parallel connection does not furnish enough voltage.

To overcome this difficulty, the series-parallel arrangement can be used if there are enough cells. If you have only a few the series connection must

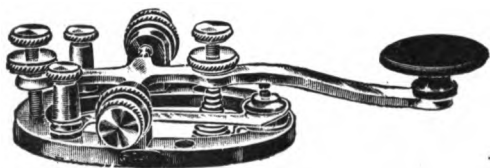

Fig. 12.—A Telegraph Key by Means of Which Dots and Dashes Are Sent.

be used. In series-parallel, the voltage depends upon the number of cells in series and the current upon the number of series rows. If, for example, 6 volts is required to run a coil, four $1\frac{1}{2}$ -volt batteries in series will produce the result. Now, if 2 rows of 4 batteries are wired in parallel, one-half of the current needed will be taken from each row, and they will last longer.

You will find that, after dry cells have been used steadily for some time, they seem to give out. After a rest of an hour, though, they will come back

again. For this reason it is not advisable to run a coil continuously, for a long time, but intermittently, so as not to ruin the batteries.

A storage battery is really an economical investment, though expensive at the start. A 6-volt, 30 or 40 ampere-hour battery gives much better results than dry cells. On one charge it will run a 1-in. spark coil 15 to 20 hours. The cost of re-

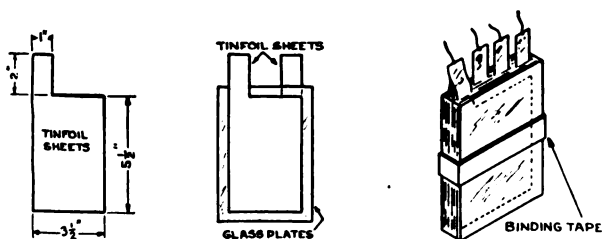

Fig. 13.—Details of the Glass-Plate Transmitting Condenser.

charging should not be over 25 cents. With the present cost of dry batteries a few renewals will more than pay for a storage battery.

Telegraph Keys.—Some means for interrupting the current into dots and dashes is required. A simple practice key can be made from a piece of spring brass, mounted on a base, with a screw head for a contact beneath the raised end of the spring. This is not just satisfactory for regular sending, however.

A good type of key is shown in Fig. 12. Vari-

28 *Radio Experimenter's Hand Book*

ous designs are sold at different prices by supply houses. For spark coil circuits, the light telegraph key will handle the current, while for a transformer of $\frac{1}{4}$ K. W. or more a regular radio key is required. The sparking gradually wears the contact points, so that occasionally they should be sand-papered slightly. A remedy for sparking is to connect a $\frac{1}{2}$ mfd. condenser around the contacts of the key.

Condenser.—For the experimenter who wants to make his own condenser, the glass plate type is the best. Ordinary window glass is not good, for it has flaws and is not electrically strong. A 5x7-in. photographic plate can be obtained for nothing from any photographer. Eleven are needed. Also a large piece of heavy tin foil is required. This is cut to the shapes shown in Fig. 13, and laid smoothly on the glass, first a glass plate, then a sheet of tinfoil, with the tabs first on one side and then on the other.

Next they are connected, as shown in Fig. 14. All of one set of taps are put together and soldered lightly. The first two of the other set are joined, and the others left separate. Small wires are soldered on for connection to binding posts and switches, as shown in the circuit diagram. Finally, the condenser is put in a wooden box with the switches on the front. The space left in the case is filled with paraffin.

When you examine Fig. 14 closely, you will see that, by closing the switches, you add sections of

the condenser and increase the capacity. A condenser of this sort is for use with spark coils up to two inches. For transformer sets, it is best to purchase a moulded or mica condenser of 0.005 to 0.007 mfd. capacity.

Spark Gap.—It is necessary to have a regular spark gap, preferably one which has zinc points, of about the construction shown in Fig. 15. A

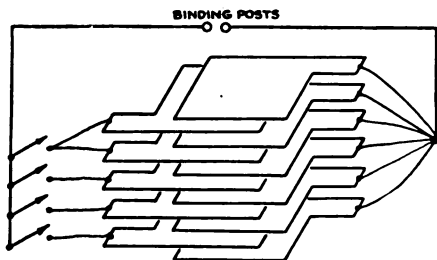

Fig. 14.—The Number of Plates in Use is Controlled by Four Switches.

wooden base can be used, but it is advisable, to prevent leakage from damp wood, to have a bakelite base. Bakelite is black, similar to hard rubber in appearance, yet far superior for all radio work. Some experimenters make simple spark gaps from two double binding posts, putting the spark electrodes through the upper holes, and making connections at the lower ones. It is a decided advantage to have a screw adjustment on one side. To accomplish this, you can thread the upper hole of

30 *Radio Experimenter's Hand Book*

one post with an 8-32 tap, and put a short piece of 8-32 rod through it, as in Fig. 16. The electrodes should be about $\frac{3}{8}$ in. in diameter and $\frac{3}{4}$ in. long,

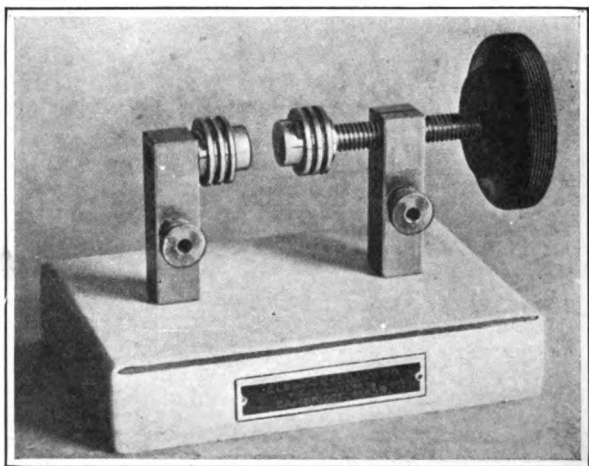

Fig. 15.—A Typical Construction for a Good Spark Gap.

with parallel faces. Battery zincs are good for this purpose.

Transformer sets require electrodes $\frac{1}{2}$ or $\frac{3}{4}$ in. in diameter. The gap must be of heavy construction with a bakelite or marble base. To keep it cool, small grooves are often turned into the electrodes, at the rear, to make radiation fins. A gap of this sort should have a heavy bakelite handle fitted to the adjustable side so that it can be adjusted while in operation.

Quenched gaps are used on commercial equipment. For experimental work, however, they are not really satisfactory, as they make such a poor note at the receiving station. Rotary spark gaps, when properly designed, are much better. When properly adjusted, they produce a clear tone. The

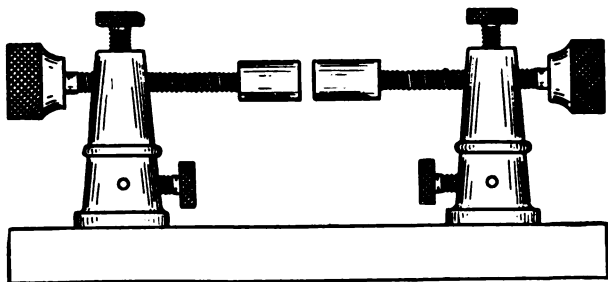

Fig. 16.—Two Binding Posts and a Little Ingenuity are the Principal Requirements for this Gap.

rotary gap is used in the same way as the fixed type previously described.

Oscillation Transformer.—In the old days, experimenters used a simple helix, but now, because of the Government regulations, an oscillation transformer is needed. The former is just a coil with eight or ten turns of heavy wire. The latter has a primary and secondary. Fig. 17 shows a type that is easy to make. Eight wooden dowels are set into a wooden base to form a circle 9 ins. in diameter. Porcelain spool insulators are

put on the dowels, and four turns of No. 14 bare copper wire wound around them. Each end is fastened to a porcelain spool by a single loop in the wire. This makes the primary.

Now the secondary is built up in a similar fashion, except that two wooden end pieces 8 ins. in diameter are used to hold the dowels, which form a 7-in. circle. Eight turns of wire are needed. A

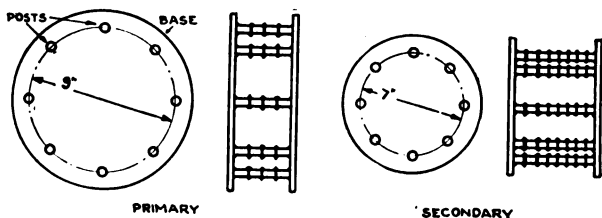

Fig. 17.—Dimensions for the Oscillation Transformer.

wooden post, 1 in. in diameter, set securely into the base, supports the secondary. If the oscillation transformer is set in a horizontal position, the secondary will stay where it is put, but in a vertical position a clamping screw is needed.

Helix clips can be made from regular spring connectors. It is necessary to use clips so that any part of any turn is available.

Transformers.—For high power, where longer distance communication is required, transformers are used in place of spark coils. They consist es-

sentially of a primary and a secondary winding on a closed, rectangular core, Fig. 18. Power is supplied from the 60 cycle, 110-volt lightning circuit.

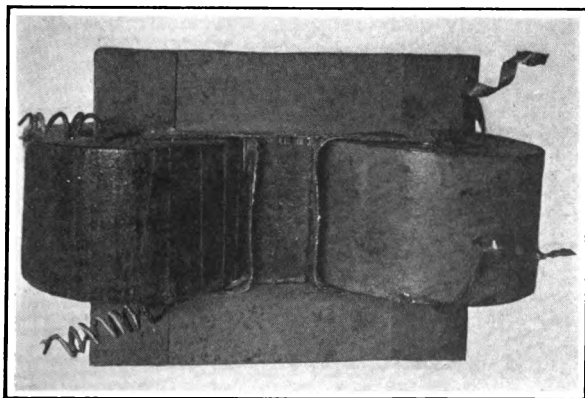

Fig. 18.—A Magnetic Leakage Transformer to Be Used on 110 Volts.

Since alternating current is used, no interrupter is needed.

Beginners in radio work are strongly advised to gain experience on a spark coil before purchasing a transformer. While there is no great danger from a $\frac{1}{2}$ K. W. transformer, there are difficulties which may arise in handling a high power set which require some previous experience.

CHAPTER IV

SETTING UP AND OPERATING A DAMPED WAVE TRANSMITTER

When you have made or purchased your sending instruments, comes the work of connecting them. Since it is still assumed that you have already put up a receiving set, it should be noted first that the transmitting equipment must be well separated from the receiver, perhaps on the opposite end of the table.

The telegraph key requires a location which is comfortable for operating. The spark coil, with its vibrator pointing forward, should be beside the condenser, with the gap, possibly, on the condenser case. Directly above, the oscillation transformer should be mounted. This grouping gives the shortest possible leads between the instruments—a very important consideration. Batteries may be in any convenient location. The entire set should be as near the antenna lead-in as can be arranged.

To tune up the station before the radio inspector comes, some means are needed to indicate the most efficient adjustments. To show why and how they are made, let us go back to our discussion of the theoretical part.

Consider Fig. 9. In the first place, the interrupter

on the spark coil must be set to give a good note without excessive sparking at the contacts. Thus the primary circuit is disposed of readily.

There are some real problems in the oscillating

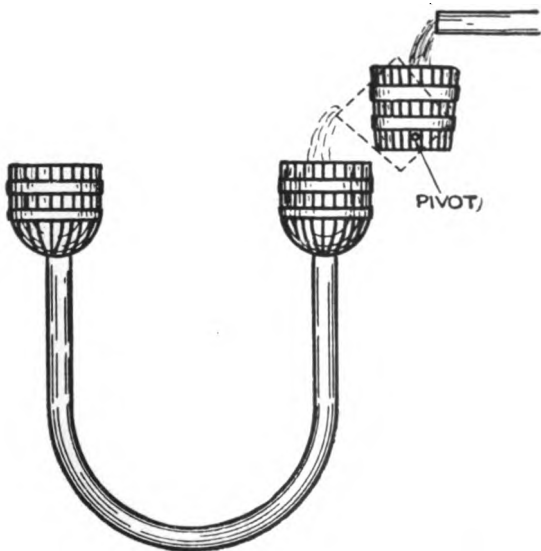

Fig. 19.—A Mechanical Analogy of the Action of a Transmitter.

circuit which includes the spark coil secondary, condenser, spark gap, and primary of the oscillation transformer. Suppose that you have a tilting bucket, Fig. 19, into which water runs. As you can see from the illustration, when the bucket is too

36 *Radio Experimenter's Hand Book*

full, it will turn over and drop the water into the U-shaped tube, and, when it does drop, it will rush down one side, up the other, and then oscillate, down on one side, up the other, back and forth, until the resistance of the tubing causes the water in the two sides to come to rest at the same level.

If the tubes were great pipes the water would surge up and down slowly, in great waves, while small tubing would cause it to jump up and down quickly.

Your tube system is quite like the radio oscillating circuit. Electricity is fed from the spark coil to the condenser, which stores it up until it can hold no more. Then, with a sudden discharge, it sends the current leaping across the spark gap, and, because the resistance of the air is broken down by the first spark, it rushes back and forth, the gap and oscillation transformer acting as the U-tube. Gradually, however, the resistance of the circuit stops the flow of current. This current movement is indicated in Fig. 3. It starts in one direction, to the right, reverses, to the left, and so on, each time a little weaker. Now you know what a damped oscillation is. To make a definition, a damped oscillation is one which dies away as it reverses.

The number of surges per second depends upon the size of the condenser and the oscillation transformer primary, or upon the amount of inductance and capacity in the circuit. If either or both of these quantities are large, the reversals will take place slowly. Reducing one or both increases the

number per second. You are not as much interested in the frequency as in the wavelength of this circuit, for the Government regulations say that the wavelength must not exceed 200 meters. The formula by which the wavelength can be found if the capacity of the condenser and the inductance of the primary are known is

$$\gamma = 59.6 \sqrt{L \times C}$$

where γ = wavelength in meters,
L = inductance in cms.,
and C = capacity in mfd.

There is no easy way to figure out these values, unfortunately. All that an experimenter can do is to make his coil and condenser of the size described in the preceding chapter and wait for the Radio Inspector to tune it by means of his wave-meter. He will determine the condenser and inductance adjustments for maximum efficiency at 200 meters.

As for the antenna circuit, which includes the antenna, oscillation transformer secondary and ground, this requires certain adjustments too. It was explained in Chapter II that the antenna and ground act as a condenser. They, with the secondary inductance, form an oscillating or radiating circuit which must be tuned to the wavelength of the other circuit.

Have you stopped to think how the current flows in the antenna circuit when it is not actually con-

38 *Radio Experimenter's Hand Book*

nected to the oscillating circuit? Just as current is induced in the secondary of the spark coil. The changing lines of force in the primary of the oscillation transformer cut the turns of the secondary and set up a current in it. But, if the two coils are too close together, the magnetic lines in the secondary react on the primary. As a result, the tuning is not sharp at the receiving set, and the

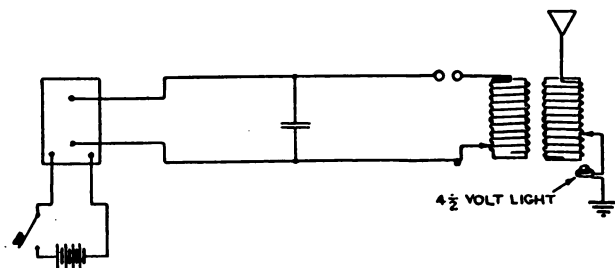

Fig. 20.—A Small Light Shows the Adjustment for Maximum Power.

transmitter cannot be tuned out to prevent it from interfering with another station which may be working at a different wavelength. The coupling between the two coils determines what is known as the logarithmic decrement, a term with which you need not worry, for the Radio Inspector will take care of that.

To tune the set temporarily, set the primary clips to include about three turns, with four condenser sections cut in. Move the secondary of the oscil-

lation transformer a little way out from the primary, and connect a $4\frac{1}{2}$ -volt light in the ground circuit, Fig. 20. When the set is operating at the highest efficiency, the light will be brightest. Now adjust the secondary clips and vary the length of the spark gap until the best results are produced. You will find that the brilliancy of the light will increase when the secondary is moved into the primary, but they should be well separated even at the sacrifice of efficiency, for if they are too close, other operators will not be able to tune out your station if it is interfering with someone else.

As soon as the station is ready to operate, you should make application for a license, as stated in Chapter XIV.

CHAPTER V

APPARATUS USED IN SIMPLE DAMPED WAVE RECEIVERS

A two slide tuner set is the best type of receiver for the beginner. It is easy to operate, is very simple in construction, and costs little to construct. One advantage about a receiver is that everything can be made with a few tools, excepting the telephones.

Tuning Coil.—There are no special limits as to the size of the tuning coil. An excellent tuner is shown in Fig. 21. The coil is wound on a cardboard or G-A-lite tube, 3 ins. in diameter and 10 ins. long. The latter material is preferable because it does not shrink or absorb moisture. No. 24 single silk wire is wound on the tube for a distance of $8\frac{1}{2}$ ins. This leaves a space of $\frac{3}{4}$ in. at each end of the tube. Some experimenters use No. 24 bare wire, winding on a thread at the same time, to space the turns. Either method is good.

Holes can be drilled with an extension bit half way through the wooden coil ends, or round pieces can be cut out to fit inside the tube and fastened to the ends. Brass screws should be used, as iron parts in or near the apparatus reduce the efficiency.

Simple Damped Wave Receivers 41

Two square rods, $\frac{3}{16} \times \frac{3}{16}$ in., act as slider rods. The sliders are made of 1-in. lengths of square brass tubing with screws soldered on, as in Fig. 22.

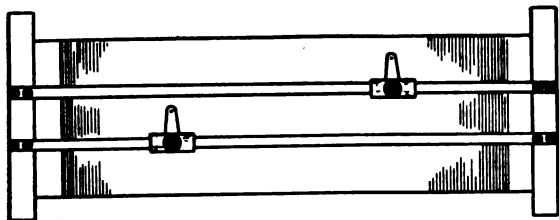

Fig. 21.—The Construction of a Two Slide Tuner.

The top ones are for small electrose knobs, while the bottom ones take the slider contacts. A small punch mark, made with a dull point, is put in each contact so that it will touch only one wire at a time.

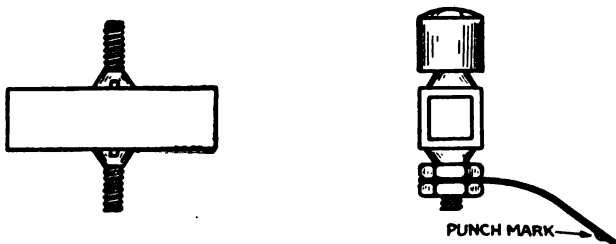

Fig. 22.—Details of a Slider for the Tuning Coil.

Three binding posts are needed, one for one end of the coil winding, and the others for connection to the slider rods. Fahnestock spring binding posts are excellent for this purpose, and cost far less

42 *Radio Experimenter's Hand Book*

than other kinds. Care must be taken to have good connections at every point, soldered, if possible.

Crystal Detector.—Many kinds of detector stands have been made. The one in Fig. 23 is easy to make and as good as any. A binding post or brass pillar supports a rod threaded at each

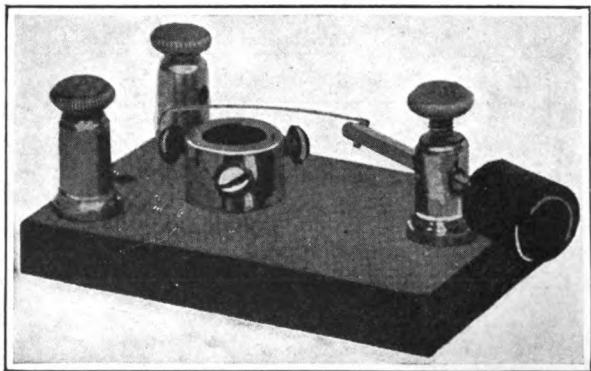

Fig. 23.—A Simple Crystal Detector.

end. The handle is fastened at one end, and a short length of No. 30 bare copper wire at the other. For test purposes, the mineral, either galena ferron, or silicon, can be set on the brass plate. It is advisable, however, to turn out a brass cup with two or three small screws put in at the side to clamp the crystal. When the detector is adjusted, the mineral is moved about until the wire touches on a sensitive spot. To prevent the col-

lection of dust on the surface of the crystal, the de Forest type, Fig. 24, has a glass case, at the top of which is a universal contact adjustment.



Fig. 24.—A Dust Proof Type Which Gives Particularly Good Results.

Some patience is required to select a good crystal. First break the mineral into small pieces about $\frac{1}{2}$ in. square. Then, with a telephone and buzzer connected as in Fig. 25, put the buzzer in operation

44 *Radio Experimenter's Hand Book*

and try out the different pieces. Do not think that the sound heard when you touch your finger to the metal parts of the detector indicates a sensitive spot. The signals will be clear and sharp when you have found a good point.

Fixed Condenser.—A small fixed condenser is needed to connect around the telephones. It is

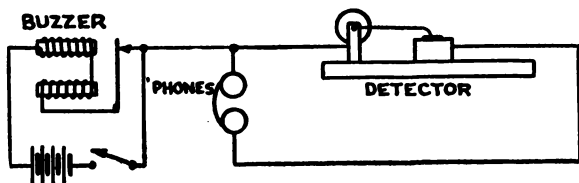

Fig. 25.—Detector Crystals Can Be Tested by Means of This Circuit.

built up in a manner similar to that used in making the sending condenser. Pieces of good bond paper are dipped in melted paraffin and cut into strips 3 ins. long and 2 ins. wide. Tin foil sheets are cut 3 ins. long and 1 in. wide. Then they are put together, as in Fig. 26, with alternate plates connected. A wooden base can be gouged out on the under side and filled with paraffin when the condenser has been set in it. Binding posts are, of course, needed.

Telephones.—The most important word to say about telephones is not to expect results from cheap, 75-ohm ones. A single phone of 1,000 ohms,

from a reputable manufacturer, will give good results. Two are better, because the signals are heard in both ears and extraneous noises are kept out. Good double head sets are sold as low as four dollars by some companies. To test phones, put a piece of wet newspaper between a penny and

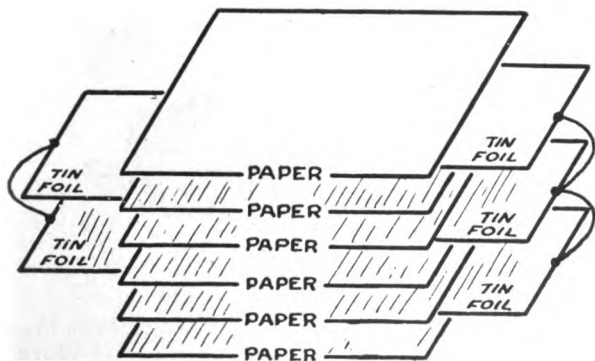

Fig. 26.—Illustrating the Method of Building Up a Fixed Condenser.

a dime. Clicks should be heard when the terminals are touched to this miniature battery.

At times, no signals or poor ones are caused by defective cords. If the trouble is present when they are first purchased, they should be taken back immediately. No company will replace phones when the experimenter has had them apart already.

De Forest Type Receiver.—The most up-to-date

beginners use de Forest honeycomb coils in place of the conventional sliding contact tuner. Fig. 27 illustrates the coils, and Fig. 28 gives the circuit diagram. A new instrument is introduced here—the variable air condenser, Fig. 29. Honeycomb coils are wound in a manner similar to that used for balls of string. This method greatly reduces

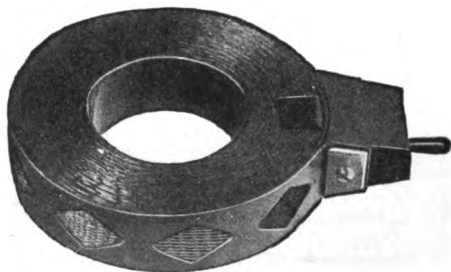

Fig. 27.—Honeycomb Coils Represent One of the Most Important Recent Advances in Experimental Work.

the resistance to high frequency currents and increases the signal strength and sharpness of tuning. No taps are taken off, for the wavelength adjustment is made by the variable condenser, a method which gives closer and more efficient tuning than any other method.

You remember that the wavelength of a circuit depends upon the amount of inductance and capacity it contains. With a two slide tuner you vary the inductance to change the wavelength; with

honeycomb coils, you vary the capacity. The latter is the better way.

Essentially a condenser is made up of two sets of plates, insulated from each other. The fixed condenser previously described had paraffined paper between the plates. An air condenser has simply the air for separation. The capacity depends upon the area of the interleaved plates. Capacity varia-

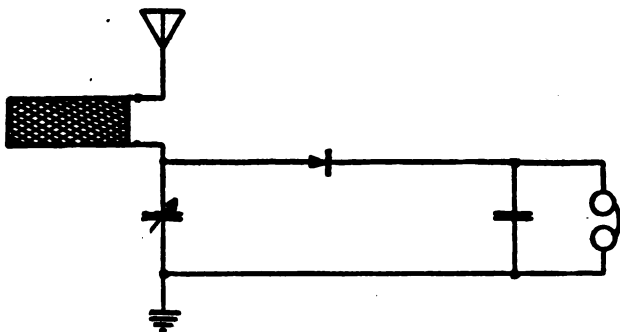

Fig. 28.—A Variable Condenser is Used for Tuning With the Honeycomb Coils.

tion is accomplished by turning the movable plates in or out of the fixed ones. If a non-variable inductance, such as a honeycomb coil, is used with a variable condenser, increasing the capacity will increase the wavelength, or decreasing will decrease the wavelength.



Fig. 29.—A Close-Up View of the De Forest Army Type Variable Condenser.

Experimental amateur stations work at 200 meters, and some commercial stations at 300 or 450 meters. A coil of 0.04 millihenry or 40,000 cms. inductance, with a condenser of 0.0005 mfd. maxi-

Simple Damped Wave Receivers 49

mum capacity will cover this range. If that coil is taken out, and a 0.15 millihenry coil put in, the condenser will tune from 500 to 800 meters. Longer waves, from 1,500 to 2,500 meters, require a 1.3 millihenry coil.

Fig. 30 illustrates a complete set made up of a



Fig. 30.—Unit Type Construction is Employed for This Receiving Set.

honeycomb coil mounting, into which any size coil can be put, a variable condenser, and a crystal detector. Used with a short range antenna, this equipment will copy signals from commercial stations up to several hundred miles. It also makes a good set for jewelers who want to copy Arlington time signals.

CHAPTER VI

SETTING UP AND OPERATING A SIMPLE DAMPED WAVE RECEIVER

The pleasure of having made a receiving set and, when the instruments are connected to have signals come buzzing in at the phones, is an experience which the experimenter never forgets. The beauty of a two slide tuner set is that it is easy to operate, and at the same time quite efficient. An important point to keep in mind is that complicated circuits are not necessarily the best for long distance work; the simpler the set the better.

There are also advantages in having a receiver which does not tune too sharply, because the closer the tuning, the more difficult it is to tune in stations which may be going. Many commercial receivers have a broadly tuned standby circuit which, when signals are heard, can be changed for sharp tuning.

Fig. 32 shows the connections for a two slide tuner. You can see that one end of the coil goes to the antenna, one slider to the ground, and the other to the detector. The telephones, shunted by the fixed condenser, goes between the detector and ground. To put the set in operation, set the sliders

near the center of the coil, switch on the buzzer test, and adjust the detector to a sensitive spot.

The best time to hear signals is at noon time, or between six and ten o'clock in the evening. If no station comes in after the set is put in readiness, put the detector slider at different points, and move

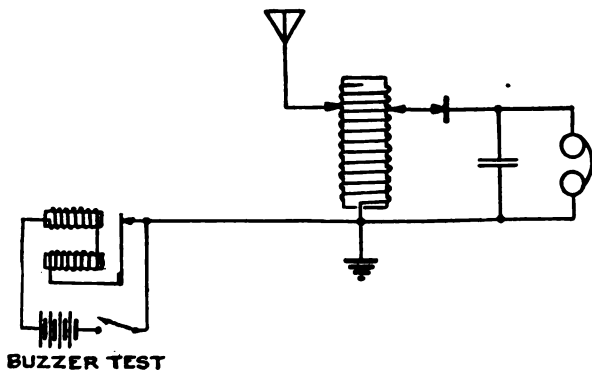

Fig. 31.—A Two Slide Tuning Coil With a Test Buzzer to Indicate the Proper Adjustment of the Detector.

the ground slider up and down the coil. Of course, it may be that no one is sending, so that this operation should be carried on for some time. After a little experience, you will know just where certain stations come in.

If you hear no messages, you must go trouble hunting. It is always a good idea to have two or three grounds at different places. Connections

52 *Radio Experimenter's Hand Book*

should be soldered at all points, if possible. Otherwise, they may come loose. Test with a buzzer between the end of the coil and the slider rods. There might be an open circuit. Wherever possible, it is a good idea to call in some fellow experimenter, as his experience may save you hours of work and discouragement.

The panels of a honeycomb coil receiver should be mounted on a board in which holes are cut, as shown in Fig. 30. To operate this set, it is only necessary, when the detector has been adjusted, to rotate the handle of the condenser until signals are heard. Different coils can be tried, depending upon the kind of stations you expect to hear. One of the great advantages of this type of set is the simplicity of operation.

Now for the theory of operation. The tuner is used with the capacity of the antenna and ground to form an oscillating circuit. As has been explained already, the wavelength of the receiver must be the same as that of the transmitter in order that the waves will oscillate at maximum strength in the receiving set.

You remember from Fig. 3 that the transmitted waves are sent out in groups of oscillations which occur at an enormous speed. If a slowly oscillating current—one of less than 10,000 cycles—is put through the magnets of the telephone receivers, the changing magnetic pull on the diaphragm will pull it down and release it, setting up air waves which we call sound. However, waves at several hun-

dred thousand a second are too rapid to cause a sound response in the telephones. Obviously, then, it is impossible for the frequency of the radio waves to make signals at the receiving set.

What you really do is to put the incoming current through the detector to rectify it. In other words, the detector opposes the flow of current during one-half of the cycle, but allows it to pass during the other. Fig. 7 shows at the current as it comes in, and the rectified current when it has passed through the detector. The result is an intermittent direct current.

A coil of wire wound around an iron core has a tendency to oppose any change of current passing through it. It tries to keep the current from starting in the first place, and then tries to prolong the current when it is cut off. The result is that an intermittent flow is smoothed out into a single impulse. The groups of high frequency oscillations occur at an audible rate, so that, when the train is smoothed out to give one pull on the telephone diaphragm, those pulls set up air waves which you can hear by your ear.

Rectification at the detector is not perfect, so that a small amount of high frequency energy flows on, but it passes through the fixed condenser instead of having to travel through the high resistance of the telephone windings.

Thus it is that radio waves, oscillating at a frequency above audibility, are made audible because they are damped out into audio frequency groups.

CHAPTER VII

RADIO ANTENNAS AND GROUNDS

Antennas are generally divided into two classes—those used for sending, and those for receiving. Since the Government Regulations limit experimental stations to 200-meter waves for sending, there are few variations for transmitting antennas. The flat top L or T is most commonly used. Fig. 32 illustrates an antenna of this type. Four wires of No. 14 gauge copper, or spreaders 10 feet long, give the best results. The lead-in should be as short as possible, and taken off at a point nearest the room where the apparatus is located. The length plus the average height should not exceed 100 to 120 feet. Neither dimension should be too predominant. A good arrangement is to have the wires 60 feet long and 40 feet high.

When the antenna is put upon the roof of an iron-framed building or apartment house, the effective height is much less than the actual elevation of the wires above the earth, so that a little experimenting is necessary to determine what length will give a 200-meter wavelength. Poles 15 to 20 feet high provide sufficient elevation over the roof.

Umbrella antennas lend themselves to mounting

conditions under some circumstances. In Fig. 33 an aerial of this sort is shown. An iron pipe or sheet iron gutter pipe can be used if it is well in-

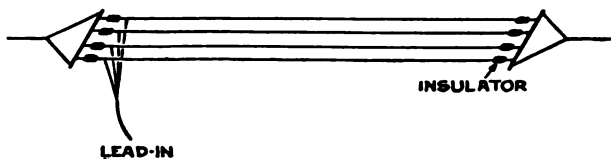

Fig. 32.—An Excellent Antenna for Receiving or Transmitting.

insulated at the bottom. Then the wires can be soldered to it, and the lead taken from the foot of the mast. With a wooden pole, the wires are in-

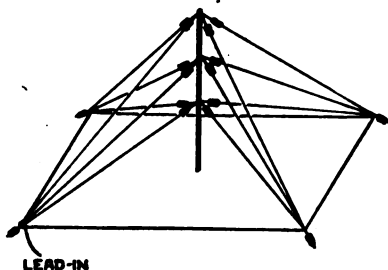

Fig. 33.—The Guy Wires Form the Antenna in This Type.

insulated top and bottom, but connected together at the bottom, and the lead brought off at the foot of the nearest set of wires.

Transmitting efficiency depends largely on the insulation. For spark coil sets, a four wire antenna should have two porcelain cleats in series at the ends of each wire, and two in series at each end of the entire antenna. Or one electrose strain insulator can be used in place of a set of porcelain cleats. Umbrella aerials require two cleats at the

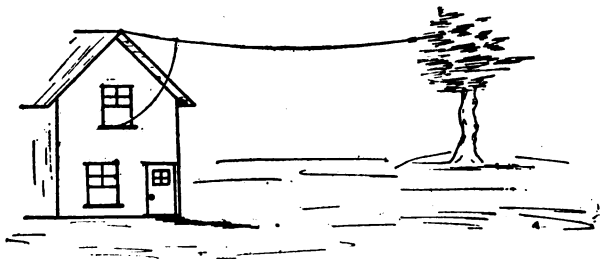

Fig. 34.—A Short Range Antenna for Receiving.

end of the wires, and an electrose mast insulator if a metal pole is used.

A $\frac{1}{4}$ K. W. transformer set calls for a 6-in. electrose insulator in place of each pair of cleats; up to 1 K. W., 10-in. insulators are required.

Lead-in insulation is also of great importance. $\frac{1}{4}$ -in. high tension cable, put through a porcelain tube, gives enough protection for spark coils. Electrose lead-in insulators must be used for transformer sets. Some experimenters make a small hole in the center of the window pane to take the lead.

Lightning switches are a common source of loss. Particularly for sets of $\frac{1}{4}$ K. W. and over, it is advisable to take the switch parts off the base and mount them on corrugated Electro-se pillars.

All kinds of aerials are used for receiving. However, the most satisfactory and the least expensive are the long, low, single wire types. The standard sizes are referred to as Short, Long, and Super Range. They are all 30 feet high and 100, 200



Fig. 35.—Antennas Are Provided for Transmitting, and Short and Long Wave Reception.

and 300 feet long, respectively. Fig. 34 shows the arrangement of the antenna. The short range size is principally for 200 to 1,000 meter reception, a wavelength range which includes experimental and short wave commercial stations. Long range antennas are for wavelengths up to 5,000 meters, and super range aerials for 20,000 meters or more. It is advisable, in order to cover all wavelengths, to have a short range and super range antenna stretched out 30° or more apart, and they should

be at an angle to the sending antenna. Fig. 35 suggests a layout.

Of course, the sending aerial, whether of the flat type or umbrella type, can be used for receiving. There is, however, very little to be gained by having a number of wires or a great elevation for receiving. Porcelain cleats for the antenna, and a

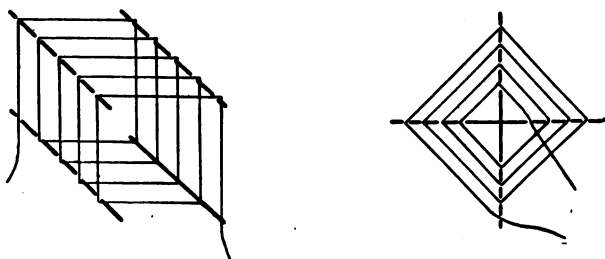

Fig. 36.—Two Types of Loop Antennas.

porcelain tube for the lead-in, give sufficient insulation for receiving purposes.

Loop antennas have come into wide use, partly because of their marked directional effect. Two types are illustrated in Fig. 36. The flat and box types are equally efficient, and have the same directional characteristics. No ground connection is used for a set working with a loop, and lightning protection is not needed. On the other hand, a loop is not as good for long distance as the single wire. In fact, a loop set with only a crystal detector will receive high powered stations for only

a few miles. For long distance reception, an audion amplifier of two or more steps is needed.

A box loop for short wave work can be made of 10 turns of annunciator wire $\frac{1}{4}$ in. apart, on a frame 3 feet square. A loop of 50 to 100 turns, 4 feet on a side, will copy the long wave stations.

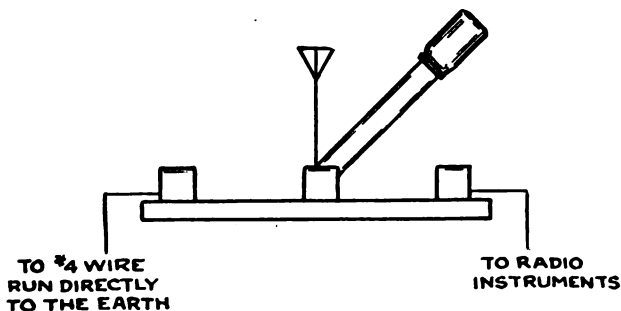

Fig. 37.—Connections for the Lighting Ground.

A pivot must be arranged so that the loop can be swung in an arc of at least 90° .

When the loop is turned until the signals are at maximum intensity, the transmitter must lie in the plane of the loop. The direction is indicated by the position of the horizontal turns, yet if, for example, the loop points north and south, as far as the operator can tell, the sending set may be to the north or to the south. An actual determination can be made by means of the unilateral radio compass, but that equipment is beyond the scope of this book.

60 *Radio Experimenter's Hand Book*

(Complete information on that subject is given by the author in an article in *Everyday Engineering*, November and December, 1919.)

Ground connections are often neglected. Experimenters do not realize always that a good ground is as important as a good antenna. The connection for receiving or transmitting should be as near the operating room as possible, and of heavy wire. The joint must be soldered—a clamp is not good enough. Pipes containing water are always safe. Oftentimes the tin pipes of a hot air furnace are good, or a steam pipe may be all right. The best plan is to ground the set at several different places.

The Fire Underwriters require a lightning ground switch, just outside the window of the operating room. The rules call for a 100-ampere, 250-volt S. P. D. T. switch, connected as in Fig. 37. The lightning ground wire must be of No. 4 copper, run directly to the earth connection, Fig. 37. This may consist of a large metal plate buried in moist earth, or simply the frame of the building if it is an iron framed structure. Although many stations have operated for years without such protection, it is advisable to make this provision against possible danger.

CHAPTER VIII

ADVANCED DAMPED WAVE RECEIVING APPARATUS

By the time you have passed through the two slide tuner stage, you will want a better receiving station, one which will work over a good range, tune sharply, and bring in the long wave spark or damped stations.

There is little advantage in making a very large coupler if only damped waves are to be received. Undamped reception, taken up in Chapter XIV, requires the use of an audion, a still more advanced stage of the game. As a matter of fact, it is generally better to have a small coupler with honeycomb type loading coils, because, on account of their exceptional efficiency and the small space they occupy, they can be worked so conveniently into a long distance receiver.

Originally, loose couplers were always made with the primary and secondary coils wound on long cylinders, but the honeycomb coils are small and compact, as you can see from Fig. 27. This coil, 4 ins. outside diameter and 1 in. wide, has an inductance equal to the 2- or 3-foot cylinders which were so popular a few years ago. The new method of loose coupler construction is shown in Fig. 38.

Instead of using switches and taps on the coils, it is only necessary to plug in whatever primary

62 *Radio Experimenter's Hand Book*

coil and secondary coil are needed for the required wavelength range. Consider Fig. 39. The antenna is connected to one end of the primary, while the other goes to the ground, with a variable condenser around the coil. The condenser gives a

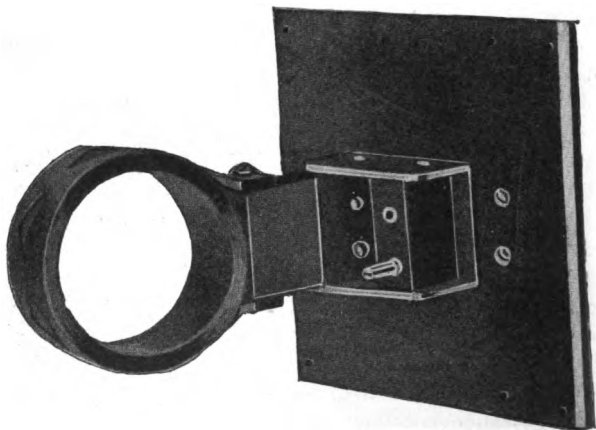

Fig. 38.—Two Coils Can Be Mounted in This Device for a Loose Amplifier.

closer adjustment than can be obtained with switches, and does away with all dead-end losses. Tuning in the secondary is accomplished in the same manner.

You must do a little careful thinking to pick out the right coils for your particular purpose. Table I is called a calibration table because it gives the wavelength ranges with various sizes of coils, and

Damped Wave Receiving Apparatus 63

different amounts of condenser capacity. Three sizes of condensers are ordinarily used—0.0001 to 0.0005 mfd., 0.0001 to 0.001 mfd., and 0.0001 to 0.0015 mfd.

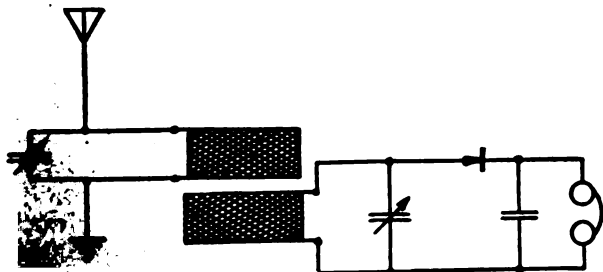

Fig. 39.—Connections for the Honeycomb Coil Loose Coupler.

CALIBRATION TABLE FOR HONEYCOMB COILS

L	Wavelength range with 0.0001 to 0.0005 mfd.		Wavelength range with 0.0001 to 0.001 mfd.		Wavelength range with 0.0001 to 0.0015 mfd.	
	MHS	METERS	METERS	METERS	METERS	METERS
0.04...	125 to	250	125 to	375	125 to	450
0.75...	175 to	350	175 to	525	175 to	625
0.15...	240 to	525	240 to	725	240 to	900
0.3....	325 to	750	325 to	1,025	325 to	1,250
0.6....	450 to	1,050	450 to	1,475	450 to	1,800
1.3....	700 to	1,525	700 to	2,150	700 to	2,560
2.3....	900 to	2,025	900 to	2,800	900 to	3,525
4.5....	1,300 to	2,850	1,300 to	4,000	1,300 to	4,900
6.5....	1,550 to	3,400	1,550 to	4,850	1,500 to	5,900
11.0...	2,000 to	4,425	2,000 to	6,300	2,000 to	7,700
20.0...	2,700 to	6,000	2,700 to	8,500	2,700 to	10,400
40.0...	4,000 to	8,500	4,000 to	11,400	4,000 to	14,600
65.0...	4,800 to	9,800	4,800 to	15,300	4,800 to	18,600
100.0...	6,000 to	13,400	6,000 to	19,000	6,000 to	23,200
125.0...	6,700 to	15,000	6,700 to	21,200	6,700 to	25,000
175.0...	7,900 to	17,600	7,900 to	25,000	7,900 to	30,600

64 *Radio Experimenter's Hand Book*

Ordinarily, for short wave receivers, 0.0001 to 0.0005 mfd. condensers are used for both primary and secondary circuits. Long range receivers generally have 0.0001 to 0.001 mfd. condensers. First, in selecting the proper coils, it should be remembered that both circuits should tune to the same wavelength. That is, if the primary range is, for example, from 5,000 to 10,000 meters, the secondary should have approximately the same range.

To select the coils for a loose coupler, let us take the following examples:

Short Wave Receiver.—A short wave receiver is generally considered to be one covering 200 to 2,500 meters. Fig. 39 brings in a new consideration—antenna capacity. With a short range antenna, the capacity can be taken as approximately 0.0003 mfd. You can see that the antenna capacity is in parallel with the tuning condenser, and, therefore, the total capacity in the circuit is the sum of the two.

Hence, if the antenna is 0.0003 mfd., and the condenser 0.0001 to 0.0005 mfd., the capacity is 0.0004 to 0.008 mfd. Referring to Table I, you will see that a 0.04 mh. coil, with 0.0005 mfd., gives 250 meters. 0.0004 mfd. will bring the wavelength down to 200 meters, for experimental stations. At maximum capacity, which is nearly 0.001, the wavelength will be about 325 meters. That is, with a 0.04 mh. coil, the condenser will tune from 200 to 325 meters. The next coil, with minimum capacity, must go down as low as 325 meters, to

Damped Wave Receiving Apparatus 65

make an overlap of wavelengths. A 0.075 coil will go down to 300 meters, and up to about 450. When this process of selection has been carried to 2,500 meters you should make a primary wavelength table such as this:

PRIMARY WAVELENGTH TABLE

SHORT WAVE RECEIVER

<i>Coil</i>	<i>Range</i>
0.04 mh.	200 to 325 meters
0.075 mh.	300 to 450 meters
0.15 mh.	450 to 650 meters
0.30 mh.	650 to 950 meters
0.60 mh.	950 to 1,300 meters
1.30 mh.	1,300 to 1,900 meters
2.30 mh.	1,800 to 2,550 meters

The secondary has only one condenser of 0.0001 to 0.0005 mfd. The table shows the coils needed to be:

SECONDARY WAVELENGTH TABLE

SHORT WAVE RECEIVER

<i>Coil</i>	<i>Range</i>
0.075 mh.	175 to 350 meters
0.30 m.	325 to 750 meters
1.30 mh.	700 to 1,525 meters
4.50 mh.	1,300 to 2,850 meters

• Suppose that you want to tune in an experimental station, operating on 200 meters. Put a 0.04 mh. coil in the primary and a 0.075 mh. coil in the secondary. Move the adjustable coil so that it is near the other, for close coupling, and rotate the

66 *Radio Experimenter's Hand Book*

condensers until the signals come in. If there is any interference, move the coils apart and readjust the condensers. The signals are not as loud, but the tuning is sharper with loose coupling.

For other stations, coils having the corresponding wavelengths are put in the mounting plugs. This accomplishes the same result as using switches on tapped coils, at the same time cutting out dead-ends and giving sharper tuning.

An examination of Table I shows that fewer coils are needed, for a given range, if larger condensers are used. With 0.0001 to 0.001 mfd. condensers in both primary and secondary circuits, the wavelength tables will be:

PRIMARY WAVELENGTH TABLE

SHORT WAVE RECEIVER

<i>Coil</i>	<i>Range</i>
0.04 mh.	200 to 450 meters
0.15 mh.	450 to 850 meters
0.30 mh.	650 to 1,150 meters
0.60 mh.	950 to 1,650 meters
1.30 mh.	1,400 to 2,500 meters

SECONDARY WAVELENGTH TABLE

<i>Coil</i>	<i>Range</i>
0.075 mh.	175 to 375 meters
0.30 mh.	325 to 1,025 meters
2.30 mh.	900 to 2,800 meters

A total of eight coils are needed instead of eleven, as was the case when 0.0005 mfd. maximum condensers were used. The tables given here can be used as a guide in the purchase of coils and condensers.

Damped Wave Receiving Apparatus 67

Long Wave Receiver.—Nowadays, there are not many transmitting stations using damped waves of much over 5,000 meters. It is not necessary, therefore, to have a greater wavelength range for a long, damped wave receiver. It is perfectly possible, of

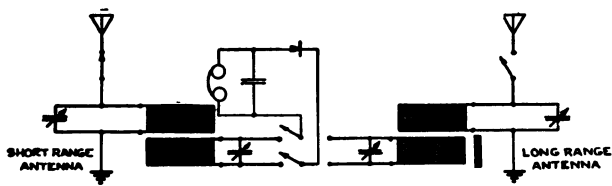

Fig. 40.—The Telephones and Detector Can Be Switched from the Long Wave Receiver to the Short Wave Set.

course, to increase the wavelength of the short wave receiver by using still larger coils.

A better method is to have a separate long range antenna which can be switched in in place of the short range one. The capacity of a long range aerial is about 0.0005 mfd., so that, with a 0.0001 to 0.001 mfd. antenna condenser, the actual capacity variation is 0.0005 to 0.0015 mfd. Now the table is:

PRIMARY WAVELENGTH TABLE

LONG WAVE RECEIVER

<i>Coil</i>	<i>Range</i>
2.3 mh.	2,000 to 3,525 meters
6.5 mh.	3,400 to 5,900 meters

68 *Radio Experimenter's Hand Book*

A 0.0001 to 0.001 mfd. secondary condenser gives a table:

SECONDARY WAVELENGTH TABLE

LONG WAVE RECEIVER

<i>Coil</i>	<i>Range</i>
11.0 mh.	2,000 to 6,300 meters

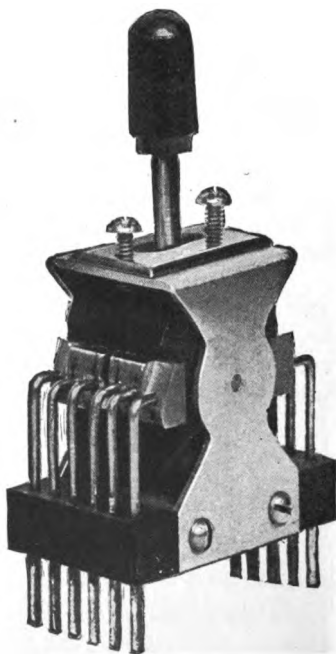

Fig. 41.—This Switch is Specially Designed for Radio Circuits.

You can see that only two primary coils and one secondary coil are needed for the long wave receiver. If you want to have two separate antennas and tuning circuits with one detector, you can connect the instruments as in Fig. 40. It is advisable to open the antenna circuit of the set not in use. The switch shown in Fig. 41 provides an excellent method for changing over the detector circuit given in Fig. 40. It is really a double pole, double throw switch. This particular construction cuts down capacity effects between the parts of the switch.

CHAPTER IX

HOW DOES AN AUDION WORK?

The audion detector, first brought out by Dr. Lee de Forest, is the most interesting instrument which has been developed during the progress of radio art. The Audion, with special variations in design, is used for detecting minute currents, amplifying and for the generation of undamped oscillations. In the succeeding chapters the two latter uses will be taken up. The purpose of this chapter is to show how and why the Audion makes it possible to detect, through the use of telephones or other indicating devices, currents so minute that they can be classed, in point of greatness, with such things as the amount of heat received on the earth from a distant star. The Audion detector, used so commonly in commercial and experimental stations, is one of the most sensitive instruments known to science, yet there is nothing delicate about its construction, nor does it require more than an elementary knowledge to use it for radio work.

It is impossible to conceive the benefit which has come to the electrical industry from Dr. de Forest's research which produced the first audion. Others

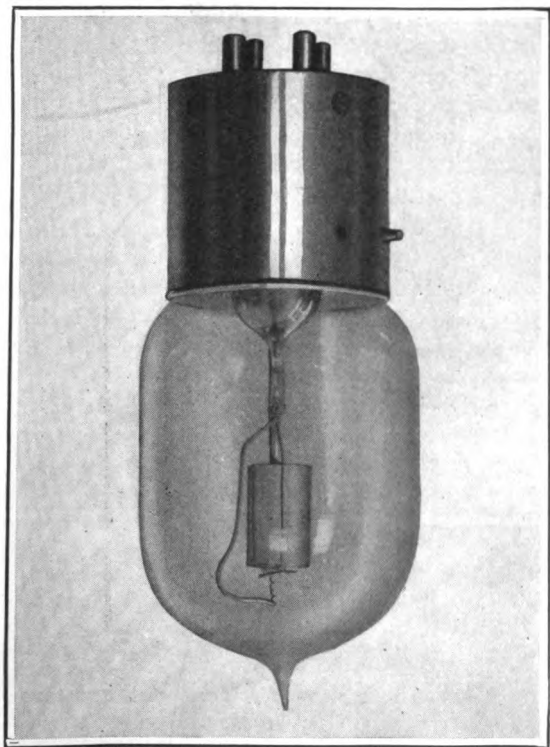

Fig. 42.—The De Forest VT Audion in Its Developed Form.

have taken up his work, and have discovered new facts, but, unquestionably he is the one to whom

72 *Radio Experimenter's Hand Book*

the gratitude of the radio field should be first extended.

Fig. 42 illustrates the type of audion bulb now licensed for the use of experimenters, while Fig. 43 shows the elements of construction. Essentially,

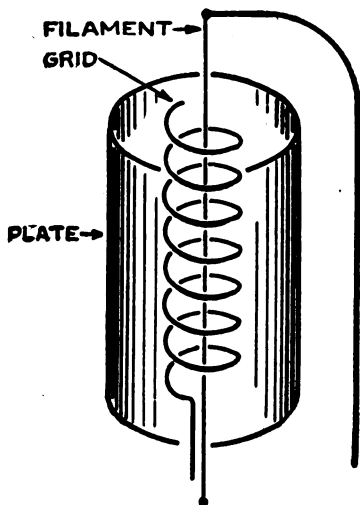

Fig. 43.—An Explanatory View of the Audion Construction.

there is a filament, heated to incandescence by a small battery, similar to that used in an ordinary electric light. A coil of wire, or grid, surrounds the filament, and, on the outside, is a cylindrical metal plate. These three elements are enclosed in

an evacuated glass bulb. A very simple arrangement, isn't it, for such a delicate device?

Now consider Fig. 44. This is not a regular radio hook-up, but a method of connection which brings out the features of the operation. You can see that there are three circuits used in connection with the bulb. First, there is the filament lighting

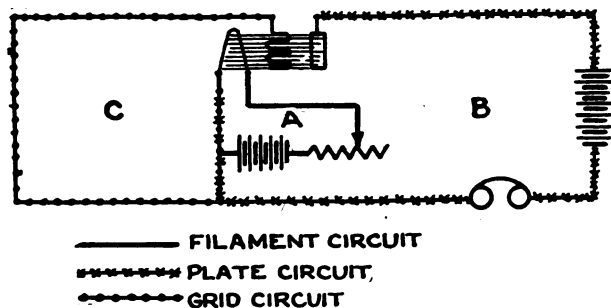

Fig. 44.—Showing the Three Audion Circuits.

or A circuit, then the plate-filament or B circuit, and, third, the grid-filament or C circuit.

When the filament is heated red hot by the A battery, it sends out tiny particles of metal from the filament, and each particle carries a charge of electricity. The action is like a fountain of salt water, for each drop of water carries a little salt. If there is nothing to affect the fountain spray, it simply shoots out into the air. However, an air suction pipe, set up near the spray, Fig. 45, will draw most of the water up from the fountain.

74 *Radio Experimenter's Hand Book*

In an audion, the plate is the suction pipe, and the B battery the blower. The negative side of the battery, connected to the filament, and the positive side to the plate, help to break down the resistance of the vacuum in the tube, so that the electrically charged particles from the filament find an easy path to the plate. The continuous flow of the elec-

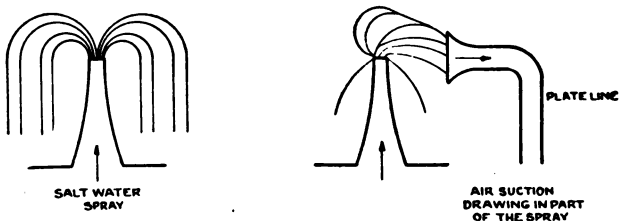

Fig. 45.—The Audion is Compared to a Salt Water Spray.

trical charges makes a steady current through the telephones.

You can understand that something else must take place in the plate circuits to have signals in the telephones, since a direct current will only hold down the diaphragm of the phones instead of making it vibrate as is necessary to produce sound waves.

Another air pipe, called the grid line, is connected with the fountain in Fig. 46. As long as the grid-line blower is not operating, the plate line will draw up the spray regularly. But, if the grid blower is rotated to suck in or blow out air, it will increase

or decrease the amount of spray drawn in. With suction, it will draw in some water itself and aid the plate line to pull up more, or, blowing out, it will scatter the spray and reduce the amount drawn in by the plate line.

Going back to Fig. 44, the grid of the Audion accomplishes the same results as the grid pipe line. As it is interposed in the path from filament to plate, any electrical charge put upon it, whether

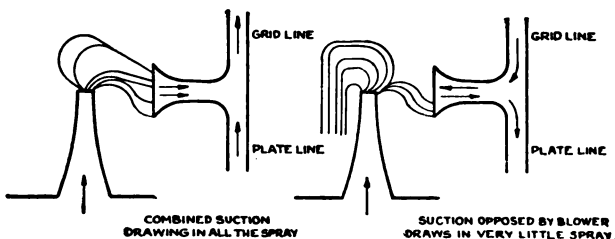

Fig. 46.—The Action of the Audion is Illustrated by This Spray and Blower System.

from a battery or a radio antenna, will either increase or decrease the plate-filament current through the phones.

There is the whole secret. The grid, when acted upon by incoming signals, changes the amount of current flowing from the filament to the plate and through the telephones. In this way, sound waves are set up.

One of the first things you will notice, when you become interested in Audion apparatus, is the num-

76 *Radio Experimenter's Hand Book*

ber of extremely complicated circuits which you will find, circuits filled with condensers, variometers, extra inductances, and all sorts of things. Always bear these facts in mind: You are handling minute currents. Every bit of energy must be put to useful work to operate the telephones. Each additional instrument means an additional loss of current going through it. Make sure that you have nothing which is not absolutely essential to the circuit. Simple sets are easier to handle and less liable to cause trouble by going out of order than complicated apparatus.

CHAPTER X

DAMPED WAVE AUDION RECEIVING APPARATUS

If, when you find the crystal detector inadequate or unsatisfactory, you have not already purchased or made a loose coupler, you can use your two slide tuner and variable condenser. Some new instruments besides the audion will be needed.

You must have a 4-volt, 20 or 30-ampere-hour storage battery, though, if you prefer, dry cells will do. However, since two sets of four cells, connected in series-parallel, are required, it is cheaper to get a storage battery at the beginning, as it can be recharged at a slight cost. A 4-volt, 20-ampere hour battery will operate one audion continuously for nearly 20 hours without recharging.

In addition, you will need a 10-ohm porcelain base rheostat. This is put in series with the audion and battery, to regulate the amount of current through the filament. It is, of course, advisable to use as little current as possible, to make the audion and the battery last longer.

There is a B battery, connected in the plate-filament circuit, of $22\frac{1}{2}$ volts. This should be of the standardized block type, either Signal Corps or Navy size.

78 *Radio Experimenter's Hand Book*

Also, a grid condenser is required. You can make this in the same manner as the fixed condenser described in Chapter V, except that a grid condenser has only four copper or tinfoil plates.

An audion socket, with the four spring contacts to make connection with the pins in the base of the bulb, can be made, though it is far more satis-

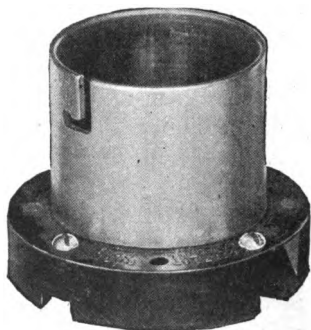

Fig. 47.—This Socket is for the Standard De Forest VT.

factory to buy it. Fig. 47 shows the standard socket. It can be set up in a vertical position or mounted horizontally.

Connections for a simple set are given in Fig. 48. Only one slider on the coil is used. The condenser is in series with the tuner and ground. Around the condenser leads are taken off to the audion. Do not put the bulb in the socket until all wiring has been completed.

You will find one of the terminals on the socket marked G. Run the lead from the grid condenser to it. The other ground end of the condenser goes to the post marked F —. To this F — post connect the — or zinc side of the battery. Run a wire from the F + connection to the rheostat, and from the rheostat to the F + or post of the battery. Next,

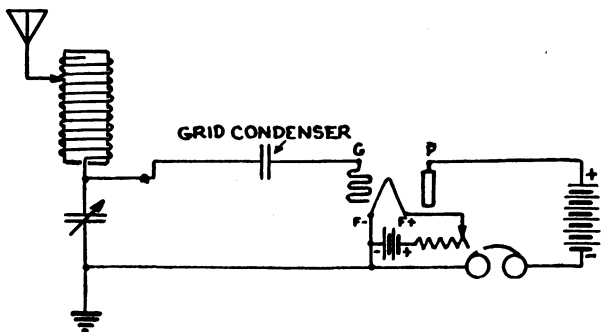

Fig. 48.—The Simplest Audion Circuit.

join the P or plate connection on the socket to the + terminal of the B battery, the — side to the phones, and, from the other tip of the phones, run a wire to the F — terminal on the socket.

When all is in readiness, adjust the rheostat to maximum resistance and insert the audion. Reduce the resistance of the rheostat until the filament burns brightly, but not with the extreme intensity that shows that it is near its safety limit.

Try your buzzer test. It should give clear sig-

80 *Radio Experimenter's Hand Book*

nals in the telephones. If it does not, disconnect one of the telephone cord tips. There should be a sharp click when it is connected again. Otherwise, examine the circuit and plate battery. The latter should show 19 to 22.5 volts.

It is possible that a connection may become loose, or one of the socket contacts bent so that it does

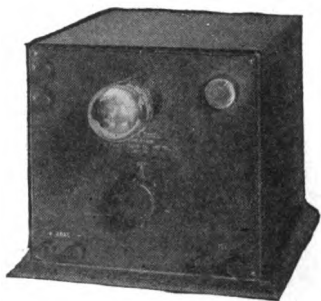

Fig. 49.—An Audion Control-Box for the De Forest VT.

not touch the corresponding pin. Perhaps the grid condenser is defective.

When everything is in order, vary the tuning condenser and coil until signals are heard. If the set has been put together properly, the signals should be much louder than with the crystal detector.

Some experimenters are under the impression that a switch or potentiometer is necessary to adjust the voltage from the B battery. With the new

de Forest VT audion this is no longer true. The first bulbs were not completely exhausted and the gas remaining in the bulb made a critical adjustment necessary. Now the new audions, similar to those used so widely by the U. S. Government, are so highly exhausted that they have no gas to make them critical.

In the early days, B batteries were made up by connecting together a number of flashlight cells. As

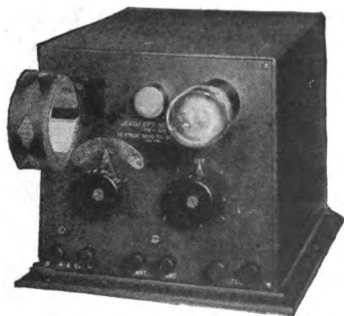

Fig. 50.—Here is a Complete Audion Receiver of the Simplest Type.

is true of the audion, batteries have been made more perfect, and special 22.5-volt types have been brought out. The small size, known as the Signal Corps type, will operate one bulb for 200 to 300 hours, while the large size or Navy type will last 750 to 1,000 hours.

Fig. 49 illustrates a complete audion control set. The bulb is mounted on the front of the panel, with

82 *Radio Experimenter's Hand Book*

an adjusting handle for the rheostat below. Binding posts are provided for the telephones, filament battery, and tuning connections. A small round metal cover can be seen in the upper right-hand corner. It contains a lead pencil mark resistance, shunted around the grid condenser. While not necessary, it improves the operation.

A complete audion receiver is shown in Fig. 50. This has a honeycomb coil in place of a tuner, with a variable condenser for tuning. As was explained in Chapter V, different coils may be inserted in the mounting plug, according to the range of wavelength desired. The set illustrated is intended specially for jewelers who wish to copy time signals. Once the proper coil has been selected, the only adjustment is the variable condenser.

CHAPTER XI

ADVANCED DAMPED WAVE AUDION RECEIVING APPARATUS

A loosely coupled set is much better in several respects than the single coil outfit described in the preceding chapter. The tuning is sharper, the signals louder, and the receiving range correspondingly greater.

The loose coupler described in Chapter VIII can be used for audion work. Coils for the primary and secondary circuits were listed in that chapter. Connections are given in Fig. 51. In this type of circuit the same tuning instruments serve for audion as well as crystal detectors.

Regenerative circuits are widely used by experimenters. Fig. 52 shows the principle upon which all regenerators work. In this case, a coil, usually called a tickler, somewhat smaller than the secondary, is connected in the plate circuit of the bulb, and coupled to the secondary of the loose coupler. The inductance of the tickler can be varied greatly without affecting the results. The changing voltage in the plate circuit is fed back to the grid side, adding to the voltage of the incoming signal. This gives a greater charge on the grid, a larger varia-

84 *Radio Experimenter's Hand Book*

tion of plate current, and stronger signals in the phones.

Another method is to connect a small variable

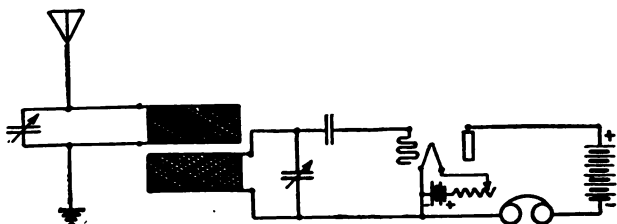

Fig. 51.—Honeycomb Coils Used With the VT.

condenser between the plate and grid. Some experimenters have variable inductances in the plate circuit, with a condenser around the telephones.

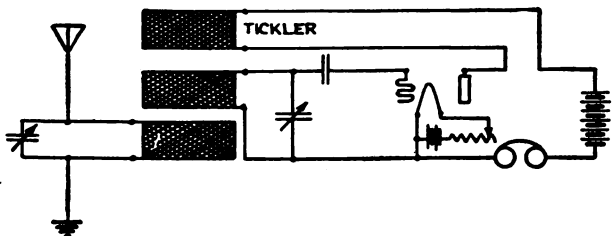

Fig. 52.—Here a Three-Coil Mounting is Employed With a Generative Circuit.

Of all these circuits, the first is the best, that is, the coupling or tickler coil. A mounting unit which can be used for such work is shown in Fig. 53,

and the circuit at Fig. 52. You can see that one outer coil acts as the primary, the center coil as the secondary, and the other outside coil as the tickler. The secondary is stationary. Moving the primary coil adjusts the coupling between primary and secondary. Swinging the tickler toward or

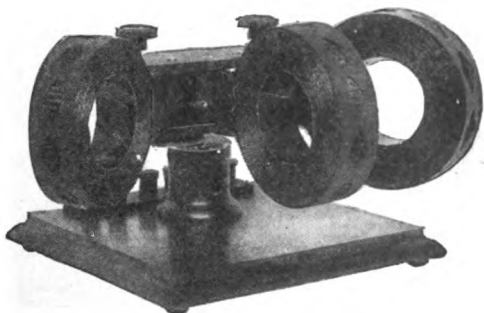

Fig. 53.—Two Handles Are Provided to Adjust the Position of the Outer Coils.

from the secondary allows the proper feed back or regenerative coupling.

When you connect a tickler coil, always bear in mind that, if the polarity is not right, it will not affect the signals. Therefore, if the tickler causes no change in the signal strength, reverse the leads. If it is working properly, it will make a buzzing noise in the phones when the coupling is too close.

The first step in setting up a regenerative damped wave receiver is to pick out the proper coils. Dif-

ferent primaries and secondaries are listed on page 65 according to the size of the tuning condensers employed and the wavelength range required. As for the tickler, on short waves it may be as large as the secondary, while for 2,500-meter reception it may be one-half or one-third as large as the secondary. The size or inductance is not specially limited by the wavelength of the signals received.

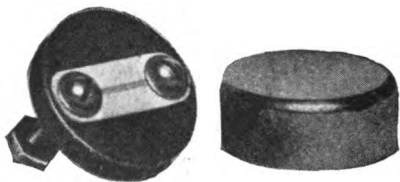

Fig. 54.—A Lead Pencil Grid Leak to Connect Around the Grid Condenser.

Looser coupling, however, is needed with a large tickler than with a small one.

To operate the set, make the primary coupling close, and adjust the tickler to the point just before that at which humming starts. As soon as a station comes in, tune with the secondary condenser, then the primary condenser, and, finally, adjust the tickler coupling. If another station interferes, loosen the primary coupling and go over all adjustments again.

Although this may sound difficult, a little experience will show just how to set the different in-

struments quickly. It is easier for you to learn to use a regenerative set than to tell you how to do it.

Trouble is sometimes encountered from howling or squealing noises in the receivers. If it is not overcome by a looser coupling of the tickler, a grid

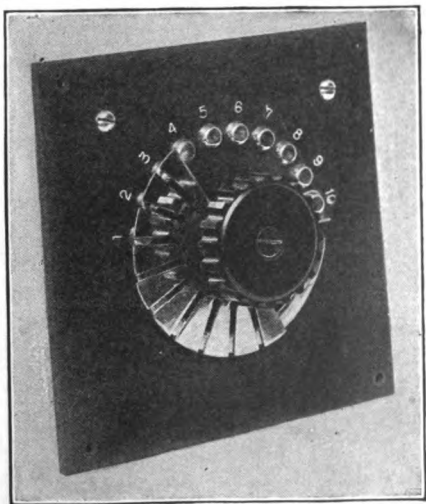

Fig. 55.—A Condenser to Shunt Around the Telephones.

leak may help. This is simply a very high resistance connected around the grid condenser. Fig. 54 illustrates the device. It is merely a strip of paper on which a pencil line is drawn. The line can be made heavier or rubbed out until the squealing stops.

88 *Radio Experimenter's Hand Book*

Another refinement is shown in Fig. 55. This is called a bridging condenser, because it is connected around the telephones and B battery. Its use in this manner will help to make the signals louder and clearer. The case contains a mica condenser of ten sections, any number of which can be put in

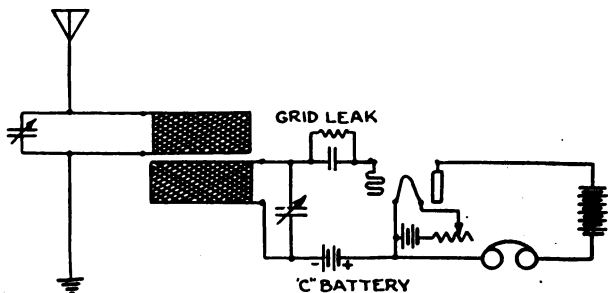

Fig. 56.—Connections for the C Battery.

the circuit by tuning the fan switch. The maximum capacity is 0.0015 mfd. If desired, this type of condenser can be used as a grid condenser, though the maximum capacity is greater than is ever needed.

Few experimenters are familiar with the C battery. This is an interesting adjustment which increases the signal strength. Fig. 56 gives a diagram of connections. Two or three cells can be connected with a switch as shown, or a single battery put directly in the grid-filament circuit. Ordinarily, the positive side of the battery must go to

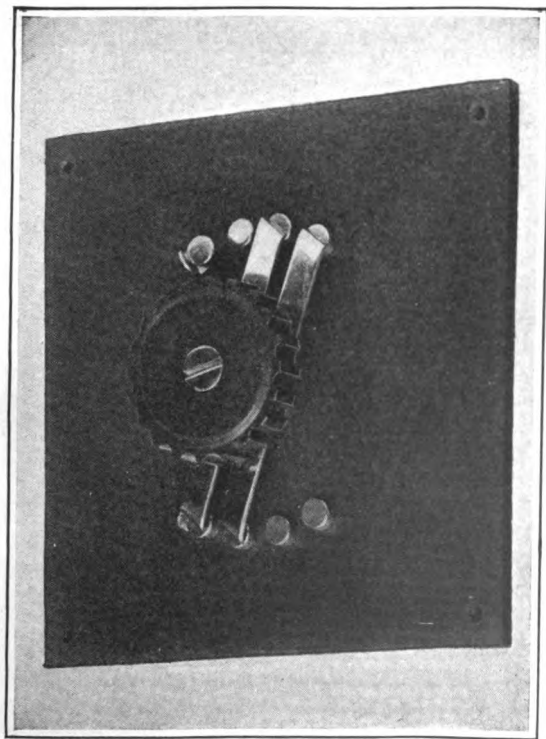

Fig. 57.—By Means of This Switch the Connections of the Condenser Can Be Changed.

the filament, yet in some cases the reverse polarity gives better results. A grid leak must be used or the C battery will have no effect.

90 *Radio Experimenter's Hand Book*

Greater wavelength range with a single honey-comb coil can be obtained with a series-parallel condenser switch connected to the primary coil and tuning condenser. When the condenser is in series

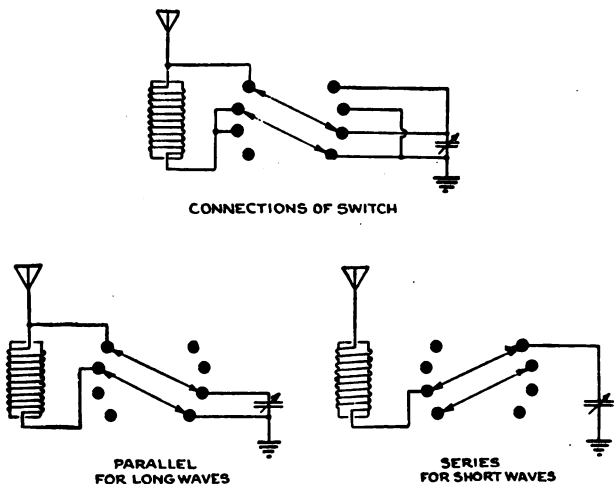

Fig. 58.—In Series the Wavelength is Reduced, While the Wavelength is Increased With the Condenser in Parallel.

with the primary, it reduces the wavelength. In parallel, shunted around the coil, it increases the wavelength. A switch of this type, Fig. 57, wired as in Fig. 58, makes it possible to change the condenser to either connection.

For short waves, the condenser is set at minimum capacity with the switch at series. When the wavelength has been brought up to maximum by increasing the capacity, the switch is put at parallel and the condenser at minimum. Increasing the capacity again will bring the wavelength up still higher.

CHAPTER XII

WHAT IS AN UNDAMPED WAVE?

Sooner or later, everyone interested in radio hears about undamped waves, continuous waves, or continuous oscillations. They all refer to the same thing. The difficulty is understanding this thing to which several terms are applied.

When you stand on the seashore, watching the waves rise in foaming surf, and spend their energy by beating on the sand, you may say that you are watching damped waves, for each one rises and expends its energy. But, if you were in a boat at sea, each wave passing would appear to move on, one after another, steadily, each wave of equal strength and size. Those would be undamped waves.

Fig. 59 gives a graphical representation of the two kinds. They are both alternating currents, increasing and decreasing in one direction and then the other. However, the damped wave is in groups or trains of oscillations, while the undamped waves follow each other in continuous oscillations of equal power.

The pendulum, swinging back and forth, is another good example. If it is struck only once a

minute, it will die out between strikes. The gradually decreasing swings are damped oscillations. On the other hand, if the pendulum is struck at each swing, it will move the same distance each time. These swings are similar to undamped waves.

It has been explained that, if radio frequency

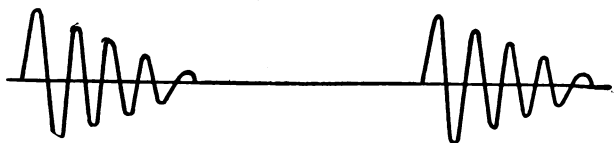

DAMPED WAVES

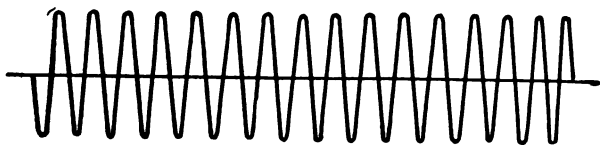

UNDAMPED WAVES

Fig. 59.—Undamped Waves Are Continuous, and Have the Same Strength.

waves are divided into audio frequency groups, they will produce audible sounds in the telephones of a receiving set. Undamped waves present a different problem, for they have no audio frequency component—only the continuous radio frequency oscillations.

One solution, the tikker, is shown in Fig. 60. The tikker is simply a brass pulley, mounted on

94 *Radio Experimenter's Hand Book*

the shaft of a battery motor, with a spring brass wire touching the pulley lightly. When the motor revolves, the wire makes an imperfect contact on the pulley. If a telephone and battery are connected in series with the pulley and wire, a scratching sound will be heard, due to the varying resistance of the contact.

Undamped waves can be received on a crystal or audion detector circuit by connecting the tikker

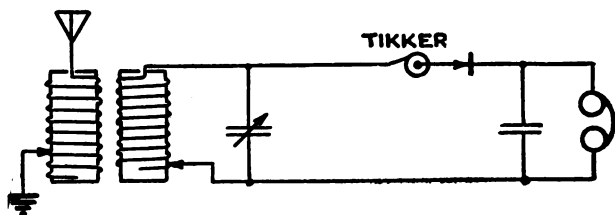

Fig. 60.—One of the Easiest Methods of Receiving Undamped Waves is by Means of the Tikker.

as in Fig. 60. Although fairly good results can be obtained in this way, a tikker is not highly efficient, since it only serves to break up the continuous oscillations.

High frequency alternators, running at speeds of 10,000 revolutions per minute, or more, are employed to generate undamped waves. Most of the undamped stations, particularly the high power ones, have Poulsen arcs, some working on 500 or even 1,000 kilowatts. These methods are beyond

the means of experimenters and will not be taken up here.

The oscillating audion, or oscillion, can be used by experimenters who have a very limited amount of equipment. Fig. 61 gives a diagram which will make clear the theory of the oscillion.

After the filament has been lighted, if the key in the plate circuit is closed, a small amount of current will flow across the plate and filament and

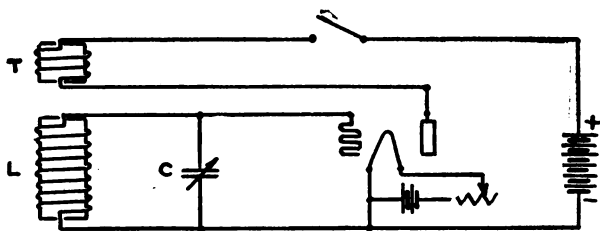

Fig. 61.—A More Satisfactory Scheme is Received in Undamped Waves by Means of the Tikler Coils.

through the small coil marked T. The current in the battery is, of course, direct, but, as the switch is closed, the rising magnetic lines of force induce a sharp kick of current in coil L, to which T is coupled. L and C comprise an oscillating circuit, so that, when a current is induced in L, an oscillation takes place at the frequency to which L and C are adjusted.

The first oscillation puts a slight charge on the grid of the audion. That, as explained in Chapter

96 *Radio Experimenter's Hand Book*

IX, changes the filament-plate current. Again the lines of force about T change, and another oscillation is set up in LC. Thus it goes, the grid circuit charging the plate current at regular intervals, de-

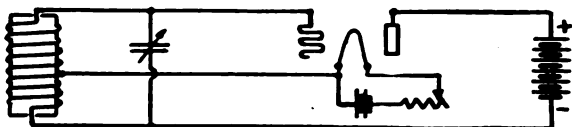

Fig. 62.—With This Circuit as the Secondary, Undamped Waves Can Be Received.

pending upon the inductance and capacity of the coil and condenser.

Various methods are used to couple the grid and plate circuits to produce undamped waves. In Fig. 62 a tap is taken off from the center of the tuning

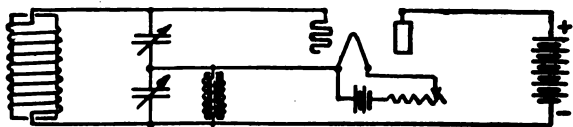

Fig. 63.—Another Way of Connecting the Instruments.

coil to the filament, while the grid is connected to one end of the coil and the plate to the other. This circuit will oscillate at any wavelength, according to the total inductance of the coil and the capacity of the variable condenser.

A different way is illustrated in Fig. 63. Here

two variable condensers are employed. Coupling is effected between the grid and plate circuits to keep the set oscillating. Changing the capacity of either condenser varies the coupling and the strength of the oscillations. Wavelength is determined by the total capacity and inductance.

Details of these circuits will be given in the following chapter.

We have not yet taken up a satisfactory method for receiving these undamped waves. If you had

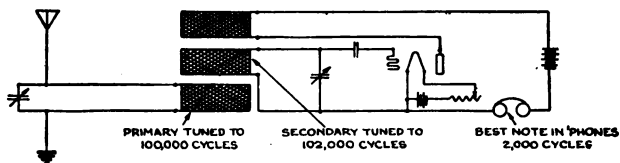

Fig. 64.—Honeycomb Coils in an Undamped Wave Receiver.

two tuning forks, one with a period of 1,000 vibrations per second and the other of 1,003, and should hold them close together while they were in vibration, you would hear a beat note or pulsing sound three times a second. This beat note would be the difference in the frequencies of the tuning forks.

Such an experiment is beyond the equipment of most experimental laboratories, but it can be carried out in a different manner with undamped waves. Suppose the primary of a loose coupler is tuned to an undamped wave of 100,000 cycles or 3,000 meters, while the secondary, connected as a

98 *Radio Experimenter's Hand Book*

generator of undamped waves, is tuned to 102,000 cycles.

Either of these frequencies are inaudible, but, when the primary and secondary are coupled together, Fig. 64, a beat note will be set up, equal to the difference in the two frequencies, in the telephones. In this case, it will be 2,000 cycles, a high pitched sound which can be heard readily and

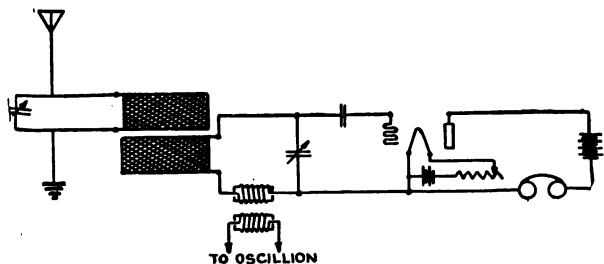

Fig. 65.—This is the Most Efficient Method.

copied easily. The frequency of the beat note can be changed by adjusting the inductance or capacity in the secondary to generate waves of a higher or lower frequency than that of the incoming signals. When the transmitting station stops, no sound is heard in the telephones because the waves generated in the secondary are above the audible range.

The interposing of one frequency upon another, to produce a third frequency, is called heterodyning. Some authorities call an undamped wave receiver, with an oscillating secondary circuit, an autodyne.

A more efficient way of receiving undamped waves is indicated in Fig. 65. It will be remembered that, in the method just described, the secondary is not exactly tuned to the primary. However, that should be done in order to receive the

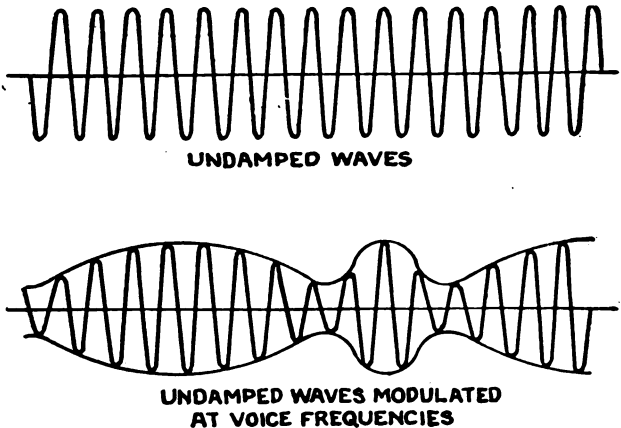

Fig. 66.—High Frequency Undamped Waves Are Modulated Into Voice Frequency Groups.

signals at maximum strength. In Fig. 65 the primary and secondary are tuned to the same wavelength, or frequency, but a separate oscillator, coupled to the secondary circuit, is used to produce beats with the incoming waves.

Detailed descriptions of the apparatus will be given later.

100 *Radio Experimenter's Hand Book*

The wireless telephone transmitter presents another problem in undamped waves. Obviously, damped waves in audio frequency groups cannot be affected by a telephone transmitter in any way to reproduce speech, for they can give but one note, depending upon the group frequency.

Undamped waves, however, could be altered into different kinds of groups to reproduce the varying voice frequencies. The effect is shown in Fig. 66. You know that direct current is controlled by varying the resistance of the carbon grains in the telephone transmitter, allowing more or less current to pass. That current, passing through a telephone receiver, reproduces the voice waves.

In Fig. 66 such a high frequency is used that a number of oscillations occur to one vibration of the voice. The strength of the oscillations are controlled by the voice operated telephone transmitter in such a manner that audio frequency variations are formed. The high frequency oscillations are called carrier waves, as they carry the modulated or voice frequencies.

Because, like the damped waves, wireless telephone oscillations at radio frequencies are divided into audio frequency groups, they can be received with an ordinary crystal or audion detector circuit.

CHAPTER XIII

UNDAMPED WAVE TELEGRAPH AND TELEPHONE TRANSMITTERS

A low-power audion telegraph transmitter is easy to make and, in several ways, is superior to spark coil or small transformer sets. The former type makes no noise, requires no dangerous, high voltages, is no more expensive, and effects a great reduction in interference. In the matter of transmitting range, a single audion set will do as well as a 1-in. spark coil, though it cannot compete, of course, with a transformer of $\frac{1}{4}$ K. W. or more. One audion, operated on two 22.5-volt batteries in the plate circuit, will send from 4 to 10 miles, depending upon the local conditions and the sensitiveness of the receiving apparatus. By using two, three or four bulbs in parallel the range can be increased considerably.

The circuit shown in Fig. 67 is good for a small undamped wave transmitter. The tuning inductance should be $3\frac{1}{2}$ ins. in diameter, wound for 4 ins. with 20 — No. 38 high frequency cable. This will give 160 turns. A variable condenser of 0.001 maximum capacity is connected in the ground circuit, and a 0.0005 mfd. maximum condenser to

the grid. Audion bulb, socket, filament battery, key and two 22.5-volt batteries complete the set. If possible, a hot wire ammeter, indicating up to 0.5 ampere, should be put in the ground lead to

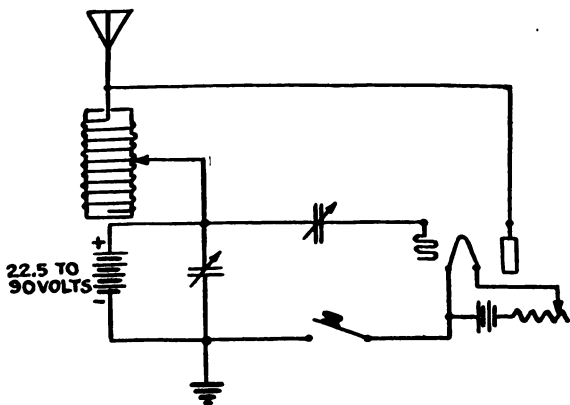

Fig. 67.—This Circuit Can Be Used for Undamped Wave Telegraphy.

show when the transmitter is adjusted to maximum efficiency.

Tuning the set is a simple matter if a hot wire ammeter is available. After the filament has been lighted, the switch on the inductance is set at about 120 turns, and the series and grid condensers varied until a maximum indication is obtained on the ammeter. Otherwise, the tuning must be done with some receiving station listening in for the maxi-

imum signal strength. The Radio Inspector will adjust the set and measure the wavelength when he examines the equipment.

Output can be increased by using a higher voltage on the plate, as the energy transmitted is taken from that source. Three or four batteries can be used as long as the bulb does not turn blue.

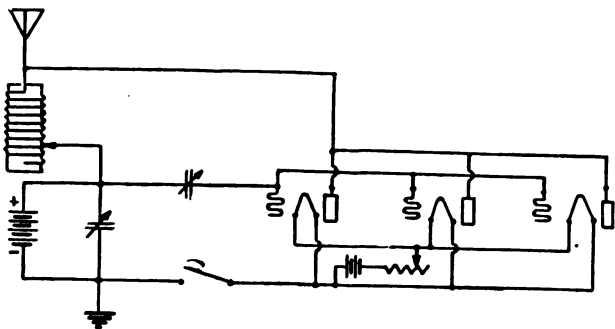

Fig. 68.—Three Audions Are Connected in Parallel to Give Greater Power.

Another way, and a more satisfactory one, to increase the range is to have two or more tubes in parallel. Fig. 68 gives a diagram of connections. The grids are wired together and also the plates, so that only one plate battery is needed. One, two, three, or four standardized 22.5-volt B batteries can be used. Two audions of the de Forest VT type will transmit six to fifteen miles by telegraph

104 *Radio Experimenter's Hand Book*

or five to ten miles telephone, depending upon the sensitiveness of the receiving station.

Fig. 69 shows a carbon grain telephone transmitter connected in the ground lead. When the key is closed, the set sends out undamped waves.

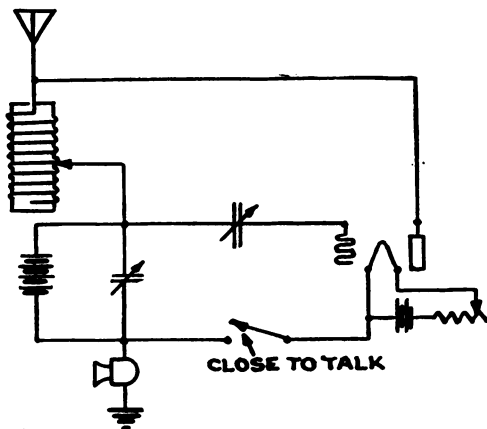

Fig. 69.—A Simple Radio Telephone Circuit.

Speaking into the transmitter modulates the oscillations so that, with a crystal or audion detector at the receiving station, clear speech will be heard. If the equipment is operating properly, the speech will be as clear or clearer than that in the wire telephone.

No variable condensers are used in the diagram at Fig. 70, as the capacity of the antenna and the

inductance of the tuning coil form an oscillating circuit. Coupling between the grid and plate circuits is obtained by the grid reaction coil. Varying the coupling changes the strength of the oscillations. A key, for undamped wave telegraphy, or a switch for telephony, is inserted in the B bat-

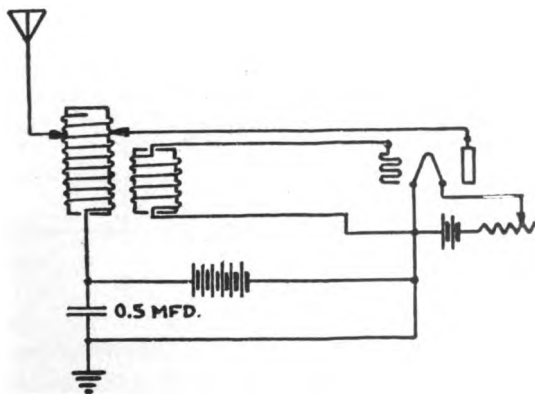

Fig. 70.—Another Way of Wiring the Apparatus for an Undamped Wave Transmitter.

tery circuit as was the case with the set previously described.

The tuning coil is $3\frac{1}{2}$ ins. in diameter, wound for four inches with 20 — No. 38 high frequency cable. Taps are taken off every 10 turns beginning with the 80th. As there will be a total of 160 turns, this means 9 taps, connected both to the antenna and plate switches. The antenna switch

Fig. 71. Either series or parallel connections can be used for the filaments, though it is generally safer to have them the latter way. Otherwise, if one tube was short-circuited, the two remaining might be burned out.

Figs. 70 or 71 can be used for telephony by inserting a telephone transmitter in the ground lead.

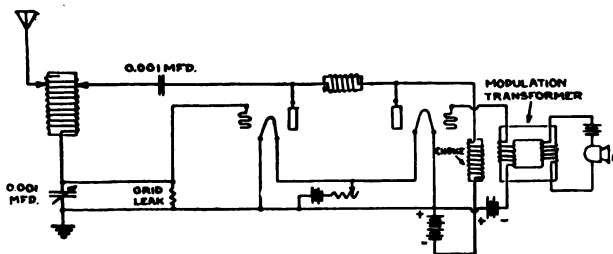

Fig. 72.—A Most Efficient Method of Wireless Telephone Transmitting is Shown in This Illustration.

If you want the very best in radio telephone apparatus, Fig. 72 is the one to use. This system has two circuits, one called the oscillator, and the other the modulator. The oscillator generates the undamped oscillations, and the modulator impresses upon the former circuit the voice frequencies.

The secret of the modulation is in the coil marked "choke." This is a large, iron core inductance of approximately 1 henry. You are probably aware of the fact that an inductance opposes

the starting of a current when the circuit is closed, and tends to prolong the flow when it is opened. The larger the inductance, the greater the time required to start and stop the current. Consequently, a direct current of varying strength is smoothed out into a steady flow when it is put through a large inductance.

Consider Fig. 73. The current from the battery

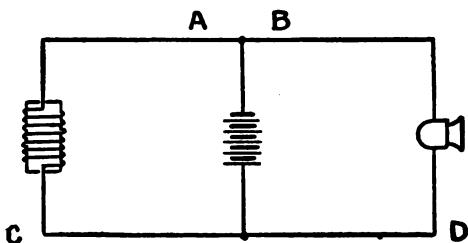

Fig. 73.—Showing That the Changing Resistance of the Transmitter Does Not Vary the Current Through the Coil.

flows through two circuits, one having a small coil, and the other a telephone transmitter. Normally, a steady current passes through the two branches. However, if the resistance of the transmitter is changed, by talking into it, the current through it will be changed, but the current through the coil will not be affected. Increasing the resistance of the transmitter will decrease the current in branch B, or decreasing the resistance will increase the current. On the other hand, that action will not

affect the coil, and no change in current will take place in A.

Fig. 74 is a different proposition. An iron core inductance is in the battery circuit. As explained, this will oppose any rapid changes of the current flow. Now what will happen when the resistance of the telephone transmitter is varied? The current in D will increase or decrease, and, since the

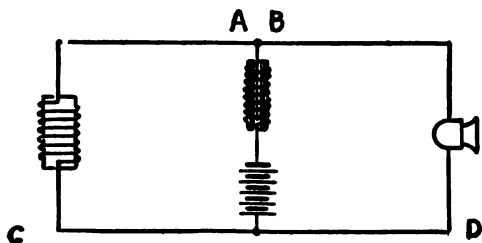

Fig. 74.—Since the Current Supply is Constant a Large Current Through the Transmitter Gives a Smaller Current in the Coil.

total current from the battery will not change, there must be a corresponding decrease or increase in C. In other words, the total current in C and D, being kept constant by the inductance, more current in D means less in C, or less in D means more in C.

This discussion seems to have nothing to do with modulation, but it actually illustrates a fundamental principle.

A modulator circuit is illustrated in Fig. 72. In the grid circuit is a modulation transformer and a

battery to give the grid a negative potential. When the transmitter is spoken into, it changes the current through the primary winding of the transformer, which, in turn, sets up an alternating voltage in the secondary, opposing or aiding the voltage of the battery. Changing the grid voltage changes the plate current. Thus, by controlling the grid voltage through the medium of a modulation transformer, the plate current is varied with the speech frequencies.

Looking back to Fig. 72, you can see that the plate circuits of the oscillator and modulator tube plates are in parallel, but they are connected to the B battery through a choke coil, in a manner equivalent to Fig. 74. Normally, the former tube is generating undamped waves. When, however, the plate current of the modulator tube is increased by speaking into the telephone transmitter, the plate current or the strength of the oscillations in the oscillator will decrease, and vice versa, because the total plate currents are kept constant by the choke coil. The result is a modulation of the undamped waves as in Fig. 66.

To make a set of this type, a tuning coil is needed of the size used for the set just previously described. The variable condenser is of the air dielectric type; other condensers are made up with paper or mica. Capacities are given in the illustration. Between the plates of the tubes is a coil of 200 turns of No. 28 s. s. c. wire wound on a thread spool. The large choke coil has 4,000 turns

of No. 28 s. s. c. wire on an iron core 4 ins. long and $\frac{1}{2}$ in. in diameter. The winding space is $2\frac{1}{2}$ ins. long, and the depth of the winding $\frac{1}{2}$ in., making the outside diameter of the coil $1\frac{1}{2}$ ins. One-half pound of wire is needed.

A battery of 3 volts is connected in the modulator grid circuit, arranged so that $1\frac{1}{2}$ volts can be used if necessary. For finer variations, a carbon potentiometer will give better results.

The modulation transformer is difficult to make and not expensive to buy. In series with the primary winding there is a battery of $4\frac{1}{2}$ or 6 volts and a telephone transmitter.

Adjustments of the set are made by varying the condenser and coil until maximum radiation is obtained at the correct wavelength. Detailed operating instructions will not be given, as more can be learned by actually experimenting with the set than by reading "Don't's and Do's." Because of the better modulation, a set having vacuum tube control will transmit farther than those with the telephone transmitter in the ground lead.

CHAPTER XIV

UNDAMPED WAVE RECEIVERS

In Chapter XII it was explained that, to obtain audible signals from undamped waves, it is necessary to impress upon them waves of a slightly different frequency. Another way of accomplishing the same end is to impress the signals upon waves generated at the receiving set.

Fig. 75 gives a circuit invented by Dr. de Forest and C. V. Logwood, one of the first and still most satisfactory for undamped wave reception. It is generally known as the Ultraudion circuit. The only difference between this and the damped wave connections is that the lower side of the secondary coil goes to the plate instead of to the filament.

The secondary of a set connected in this manner will oscillate continuously at a wavelength depending upon the inductance and capacity in the circuit. These radio frequency currents, passing through the telephones, will produce no sound in the telephones. When, however, undamped waves are tuned in the primary of the loose coupler, they will produce a beat note with the secondary oscillations, creating an audible sound.

In general, the Ultraudion circuit is best for the first experiments, because it is easy to manipulate. Honeycomb coils and tuning condensers for this

work can be selected, according to the wavelengths to be received, from the table in Chapter VIII.

Another method of undamped wave reception.

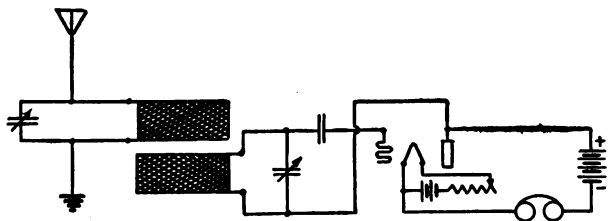

Fig. 75.—The Ultraudion Circuit for Undamped Wave Reception is an Invention of Dr. De Forest's.

a little more efficient but somewhat harder to handle, is by the use of the tickler coil. Fig. 76 shows how the instruments are wired. The three-coil

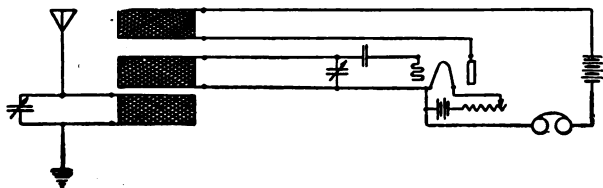

Fig. 76.—Honeycomb Coils Are Employed in This Undamped Wave Receiver.

mounting, Fig. 53, can be used for this purpose. As a matter of fact, this circuit is the same as that given for damped wave regenerative reception. The difference is only in the degree of coupling

between the tickler and secondary. This is made closer until, when one of the wires leading to the grid of the audion is touched, a plucking sound is heard in the telephones. Such a sound, easily distinguishable from others, indicates that the circuit is oscillating. Tickler coils for this work should be of the same size as those for regenerative receiving.

Damped waves can be heard on an undamped wave receiver, but, when undamped signals are coming in, their tone can be varied by adjusting the condenser. Close variation of the tuning condenser is required, as undamped waves are extremely sharp.

Various connections for undamped work can be used. Most other circuits, however, accomplish nothing more than the addition of a few condensers and coils which make tuning more difficult but do not produce louder signals.

A list of undamped transmitters is given here to show at what wavelengths they generally operate.

LOCATION	CALL	WAVELENGTHS
<i>United States and Possessions</i>		
Annapolis, Md. (Undamped)	NSS	16,900
Arlington, Va. (Undamped)	NAA	6,000
Balboa, Canal Zone (Undamped)	NBA	7,000
Cavite, Philippines (Undamped)	NPO	12,000
Guam, Marianna Is. (Undamped)	NPN	5,000
Pearl Harbor, Hawaii (Undamped)	NPM	11,000
New Brunswick, N. J. (Undamped)	NFF	13,600
San Diego, Calif. (Undamped)	NPL	13,300 and 9,800
San Francisco, Cal. (Undamped)	NPG	8,600 and 4,800
Tuckerton, N. J. (Undamped)	NWW	9,200
Sayville, L. I. (Undamped)	NDD	11,600 and 9,800
Tutuila, Samoa (Undamped)	NPU	6,000 and 3,000
Marion, Mass. (Undamped)	WSO	Undetermined
<i>British</i>		
Apia, Samoa (Damped)	VMG	2,000
Barrington Passage, N. S. (Undamped)	VCU	5,000
Bermuda, W. I. (Undamped)	BZR	5,000
Carnarvon, Wales (Undamped)	MUU	14,000
Christiana, Jamaica (Undamped)	BZQ	5,000
Clifden, Ireland (Damped)	MFT	6,000
Glace Bay, N. S. (Damped)	GB	7,500
Hong Kong, China (Undamped)	BXY	5,000
Hornsea, England (Undamped)	BWC	4,500

LOCATION	CALL	WAVELENGTHS
<i>British</i>		
Nauru, Pacific Ocean (Damped)	VKT	2,200
Poldhu, Ireland (Damped)	MPD	2,800
Punta Delgada, Azores (Undamped)	BWP	2,000
Rabaul, Pacific Ocean (Undamped)	VJZ	2,900
Singapore, Malay Peninsular (Undamped)	VPW	3,400
St. Johns, Newfoundland (Undamped)	BZM	5,000
Yap, Pacific Ocean (Damped)	—	1,800
<i>French</i>		
Eiffel Tower (Undamped)	FL	10,000
Lyons (Undamped)	YN	15,500
Nantes (Undamped)	UA	9,000 and 11,000
<i>Italian</i>		
Coltano (Damped)	ICI	6,500
Rome (Undamped)	IDO	11,000
<i>Germany</i>		
Berlin (Damped)	LP	5,500
Hanover (Eilvese) (Undamped)	OUI	15,000
Nauen (Undamped)	POZ	12,600
<i>Miscellaneous</i>		
Mexico City, Mexico (Damped)	XDA	4,000
Petrograd, Russia (Damped)	TSR	5,000 and 7,000
Stavanger, Norway (Undamped)	LCM	9,500 and 12,000
Java, Dutch East Indies (Undamped)	PMM-PMX	6,100

CHAPTER XV

THE AUDION AMPLIFIER

Still another use for the audion bulb is in amplifying signals beyond the strength obtained with a detector. You will probably hear about radio frequency amplifiers, and impedance, resistance, and capacity coupled amplifiers. The radio frequency type is used to amplify the signals before they are detected. The other three terms indicate methods of connecting an amplifier of one or more stages to the detector. Where the signals are first detected and afterward amplified, the amplifier is said to be of the audio frequency type.

Only the transformer coupled, audio frequency amplifier will be described here, for the others require special coils, condensers, and resistances which can be omitted when transformer coupling is employed. Fig. 77 gives the connections for a damped wave detector and single step amplifier. An examination of the circuit will show that the detector is wired in the usual manner, except that the primary of the amplifying transformer is put in where the telephones go ordinarily. The secondary winding goes to the grid of the amplifier tube, with the telephones in the plate circuit. Two

22.5-volt B batteries are so arranged that there are 22.5 volts on the detector plate, and 45 volts on the amplifier plate. No B battery switch or potentiometer is used, as the new VT's do not require it.

When buying audion bulbs, it is necessary to state whether they are for detectors or amplifiers, as the latter types are pumped to a higher degree

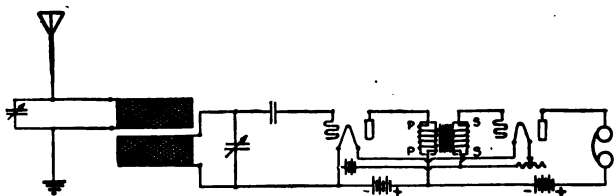

Fig. 77.—A Simple One-Step Amplifier.

of vacuum, making possible the use of a higher plate voltage.

Parallel connection of the filaments make possible the use of a single 6-volt lighting, with one regulating rheostat. However, they can be in series with a 12-volt battery and 10-ohm rheostat if that method seems to offer any advantage.

An amplifying transformer is shown in Fig. 78. This is made up of a primary and secondary winding of extremely fine wire, mounted on a closed iron core. The laminations of the core are held by clamps which also provide means for mounting the transformer on a base or panel. A bakelite

panel carries the binding posts. Because of the difficulty in winding wire as fine as No. 40—still

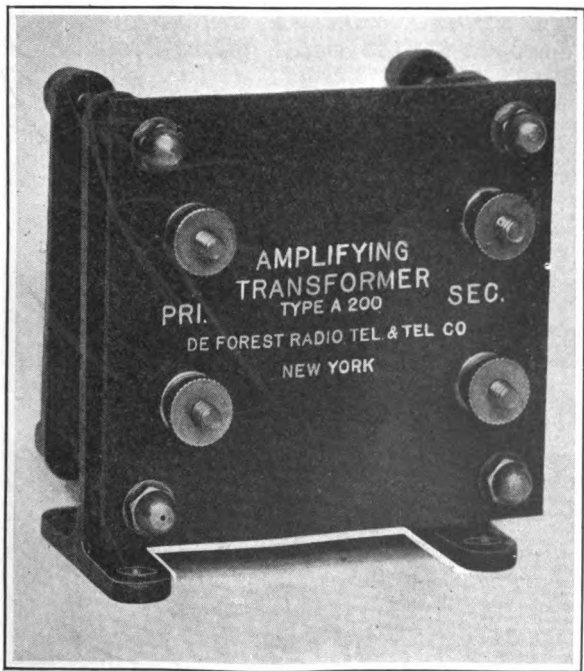

Fig. 78.—This Transformer is Used in Fig. 77.

small sizes are often used—it will be found more practical to buy an amplifying transformer than to make one.

120 *Radio Experimenter's Hand Book*

Fig. 79 illustrates a complete amplifying set, consisting of a tube socket, filament rheostat, telephone jack, filament current switch, and transformer. It is connected as in Fig. 80. This set is intended for use with a separate receiving set

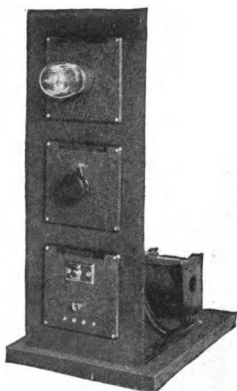

Fig. 79.—A Three Panel Audion Amplifier.

and audion detector. The primary of the transformer is wired to the detector in place of the telephones. A push and pull switch opens or closes the filament circuit. Telephones are connected by means of a plug inserted in the jack, near the bottom of the lowest panel.

Usually experimenters want to be able to receive and amplify both damped and undamped waves. Fig. 81 shows how this can be done. A switch,

generally called an audion-ultraudion switch, is put in the tuning circuit. At the audion position, damped waves can be received, or at the ultraudion

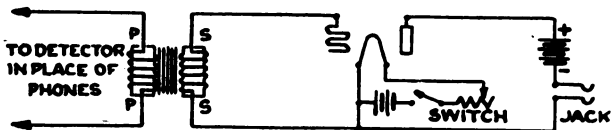

Fig. 80.—Connections for Apparatus Shown in Fig. 79.

position, undamped waves. Also, there are two filament switches and telephone jacks. To use the detector alone, the amplifier filament switch is opened and the telephones plugged in at the de-

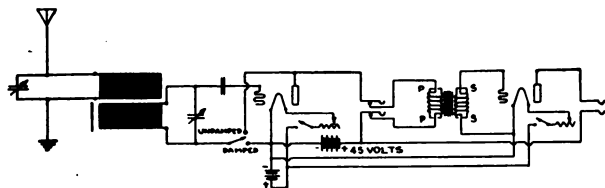

Fig. 81.—Either Damped or Undamped Waves Can Be Received and Amplified With This Set.

tector jack. Long distance work, requiring the amplifier, can be carried on by lighting the second bulb and plugging in the telephones in the amplifier circuit.

For extremely long range work, a two-step am-

plier is needed. As will be seen from Fig. 82, the second step wired like the first. The detector alone, or the first or second stage of amplification, can be used by closing the filament switches and plugging in the telephones at the point desired.

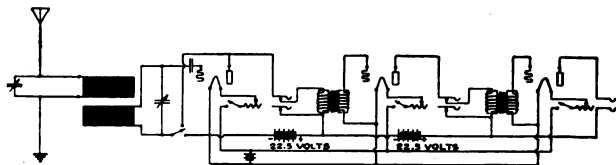

Fig. 82.—Very High Amplification Can Be Obtained With a Two-Step Amplifier.

Occasionally trouble is experienced from howling, particularly with a two-step amplifier. This is due to coupling effects between different parts of the circuits. Separating the wires, or moving the transformers farther apart, will remedy the trouble.

CHAPTER XVI

RADIO RULES AND REGULATIONS

“Don’t interfere” is the watchword of radio experimenters. The importance of this slogan cannot be overestimated. Upon its observance the continuation of experimental wireless work, and much of the development of the art, depends.

A single case of wilful or ignorant interference takes months for the other law-abiding experimenters to live down, and may result in a large fine or jail sentence. The Government officials are particularly strict about false distress signals, and justly so. Such signals are criminal.

There is no danger, however, that those who follow the few instructions given here will get into any trouble.

No license or permit is required for a receiving station. The only rules which apply to the operators of receiving sets is that they shall disclose no important information which they may copy. Such operators may take out amateur or commercial operators’ licenses if they wish, and can pass the examinations. Application blanks are obtain-

124 *Radio Experimenter's Hand Book*

able at the following cities where the offices of the District Radio Inspectors are located:

1. Boston, Mass.—Maine, New Hampshire, Vermont, Massachusetts, Rhode Island, Connecticut.
2. New York, N. Y.—New York (county of New York, Staten Island, Long Island, and counties on the Hudson River to and including Albany, Rensselaer, and Schenectady) and New Jersey (counties of Bergen, Passaic, Essex, Union, Middlesex, Monmouth, Hudson and Ocean).
3. Baltimore, Md.—New Jersey (all counties not included in second district), Pennsylvania (counties of Philadelphia, Delaware, all counties south of the Blue Mountains, and Franklin County), Delaware, Maryland, Virginia, District of Columbia.
4. Savannah, Ga.—North Carolina, South Carolina, Georgia, Florida, Porto Rico.
5. New Orleans, La.—Alabama, Mississippi, Louisiana, Texas, Tennessee, Arkansas, Oklahoma, New Mexico.
6. San Francisco, Cal.—California, Hawaii, Nevada, Utah, Arizona.
7. Seattle, Wash.—Oregon, Washington, Alaska, Idaho, Montana, Wyoming.
8. Cleveland, Ohio.—New York (all counties not included in second district), Pennsylvania (all counties not included in third district), West Virginia, Ohio, Michigan (Lower Peninsula).
9. Chicago, Ill.—Indiana, Illinois, Wisconsin, Michigan (Upper Peninsula), Minnesota, Kentucky, Missouri, Kansas, Colorado, Iowa, Nebraska, South Dakota, North Dakota.

In cities or towns far distant from a District Inspector's Office, temporary transmitting and operating licenses are often granted if the understand-

ing of the applicant seems to warrant such permission.

The Continental Code, now used exclusively for radio communication, is given below.

A	. -	U	. . -
B	- . . .	V	. . . -
C	- . - .	W	. - -
D	- . .	X	- . . -
E	.	Y	- . - -
F	. . - .	Z	- - . .
G	- -
H	,	. - . - . -
I	. .	Fraction bar	- . . - .
J	. - - -	Wait	. - . . .
K	- . -	1	. - - - -
L	. - . .	2	. . - - -
M	- -	3	. . . - -
N	- .	4 -
O	- - -	5
P	. - - .	6	-
Q	— — — — —	7	- - . . .
R	— . - . - .	8	- - - . .
S	. . .	9	- - - - .
T	-	10	- - - - -

The abbreviations listed below are widely used in radio work, and the most important, QRM, should be memorized as soon as possible.

<i>Abbreviation</i>	<i>Question</i>
PRB	Do you wish to communicate by means of the International Signal Code?
QRA	What ship or coast station is that?
QRB	What is your distance?
QRC	What is your true bearing?
QRD	What are you bound for?
QRF	Where are you bound from?
QRG	What line do you belong to?
QRH	What is your wavelength in meters?
QRJ	How many words have you to send?
QRK	How do you receive me?
QRL	Are you receiving badly? Shall I send 20 . . . — .?
QRM	Are you being interfered with?
QRN	Are the atmospherics strong?
QRO	Shall I increase power?
QRP	Shall I decrease power?
QRQ	Shall I send faster?
QRS	Shall I send slower?
QRT	Shall I stop sending?
QRU	Have you anything for me?
QRV	Are you ready?
QRW	Are you busy?
QRX	Shall I stand by?
QRY	When will be my turn?
QRZ	Are my signals weak?
QSA	Are my signals strong?
QSB	Is my tone bad? Is my spark bad?
QSC	Is my spacing bad?
QSD	What is your time?

Answer

I wish to communicate by means of the
International Signal Code.

This is

My distance is

My true bearing is.....degrees.

I am bound for

I am bound from

I belong to theline.

My wavelength ismeters.

I havewords to send.

I am receiving well.

I am receiving badly. Please send

20 . . . — .

I am being interfered with.

Atmospherics are very strong.

Increase power.

Decrease power.

Send faster.

Send slower.

Stop sending.

I have nothing for you.

I am ready. All right now.

I am busy (or, I am busy with.....

Please do not interfere).

Stand by. I will call you when required.

Your turn will be No.....

Your signals are weak.

Your signals are strong.

Your tone is bad.

The spark is bad.

Your spacing is bad.

My time is

128 *Radio Experimenter's Hand Book*

<i>Abbreviation</i>	<i>Question</i>
QSF	Is transmission to be in alternate order or in series?
QSG	
QSH	
QSJ	What rate shall I collect for?
QSK	Is the last radiogram cancelled?
QSL	Did you get my receipt?
QSM	What is your true course?
QSN	Are you in communication with land?
QSO	Are you in communication with any ship or station (or: with.....)
QSP	Shall I inform.....that you are calling him?
QSQ	Is.....calling me?
QSR	Will you forward the radiogram?
QST	Have you received the general call?
QSU	Please call me when you have finished (or: at.....o'clock).
QSV	Is public correspondence being handled?
QSW	Shall I increase my spark frequency?
QSX	Shall I decrease my spark frequency?
QSY	Shall I send on a wavelength ofmeters?
QSZ
QTA

Answer

Transmission will be in alternate order.
Transmission will be in series of 5 messages.

Transmission will be in series of 10 messages.

Collect

The last radiogram is cancelled.

Please acknowledge.

My true course isdegrees.

I am not in communication with land.

I am in communication with
(through)

Inform that I am calling him.

You are being called by

I will forward the radiogram.

General call to all stations.

Will call when I have finished.

Public correspondence is being handled.

Please do not interfere.

Increase your spark frequency.

Decrease your spark frequency.

Let us change to the wavelength of meters.

Send each word twice. I have difficulty in receiving you.

Repeat the last radiogram.

130 *Radio Experimenter's Hand Book*

Naval coast stations in the United States and Alaska, upon receiving information concerning any danger to navigation (wrecks, light vessel off station, storm warnings, etc.), immediately broadcast such information on 600 and 952 meters, and again thereafter at 8.00 A.M., noon, 4.00 P.M., and 8.00 P.M. (local standard time).

At noon and 10.00 P.M. (75th meridian time) Arlington (NAA) immediately after time signals broadcasts the same information on 2,500 meters. In addition, a Weather Bulletin is broadcasted at 10.00 P.M., which, in addition to the actual weather conditions along the coast at important points, contains weather forecasts for the North Atlantic, Middle Atlantic, South Atlantic, and Gulf Coasts.

Weather Bulletins commence "USWB" for United States Weather Bureau, and then the weather conditions are given by a number of groups of five figures, preceded by one or two letters, which are used to indicate the point from which the weather conditions are reported. (See attached list of abbreviations.) The first three figures of each group are the last three figures of the barometer reading, the third figure is the direction of the wind, where "1" indicates "NE" wind, "2" indicates "E", "3" "SE", "4" "S", and "8" indicates "N", etc. The fifth figure is the force of the wind, using Beaufort scale. Where force is above "9" it is spelled out.

Reports of the same character are also sent by Great Lakes (NAJ) on 1,512 meters, immediately

following time sent at 10.00 P.M. (90th meridian time), and by North Head, Wash., San Francisco, Cal., and San Diego, Cal., at 10.00 P.M. (120th meridian time) immediately after time signals. The Pacific Coast stations broadcast the information first on their working wave; next on 952 meters, and then on 600 meters. Reports are preceded by "USWBSF", the "SF" standing for San Francisco.

All Pacific Coast stations also broadcast their weather reports at 8.00 A.M., noon, 4.00 P.M. and 8.00 P.M. Cape Blanco broadcasts Tatoosh, North Head and Eureka weather after local report. At 8.00 A.M. and 8.00 P.M. Eureka broadcasts the 6.00 A.M. and 6.00 P.M. weather conditions at Farallones; Farallones broadcasts the 6.00 A.M. and 6.00 P.M. weather conditions at Eureka, and 7.00 A.M. and 7.00 P.M. conditions at Pt. Arguello, while, at the same time, Pt. Arguello broadcasts the 7.00 A.M. and 7.00 P.M. weather conditions at the Farallones.

ABBREVIATIONS USED

Atlantic Coast

SydneyS
 NantucketT
 Delaware Breakwater ..DB
 HatterasH
 CharlestonC
 Key WestK
 PensacolaP
 BermudaB

Great Lakes

DuluthDU
 MarquetteM
 Saulte Ste. MarieU
 Green BayG
 ChicagoCH
 AlpenaL
 DetroitD
 ClevelandV
 BuffaloF

132 *Radio Experimenter's Hand Book*

Pacific Coast

Tatoosh	T
North Head	NH
Eureka	E
San Francisco	SF
San Diego	SD

Press news, sent by spark signals, are broadcasted from the following stations:

<i>Call Letters</i>	<i>Name of Station</i>	<i>Meters</i>	<i>Time</i>
NAA	Washington, D. C.	2,500	10:00 P.M.
NAR	Key West, Fla.	1,500	10:00 P.M.
NAX	Colon, Panama	2,400	10:00 P.M.
NPG	San Francisco, Cal.	600	1:15 A.M.
KHK	Honolulu (Wahiawa)	600	11:30 P.M.
NAH	New York, N. Y.	1,500	9:00 P.M.
NPL	San Diego, Calif.	2,400	
BZM	St. Johns, N. F.	1,500	7:30 A.M.
VCU	Barrington Passage, N. S....	1,500	8:00 A.M.
BZL	Demerara, Brit. Guiana	1,300	6:00 A.M.
BZN	Falklands	4,300	3:30 A.M.
BYZ	Malta (Rinella)	2,650	9:00 A.M.
			7:00 P.M.
OAZ	San Cristobal, Peru	1,500	2:00 A.M.
BXY	Hong Kong, China	2,000	9:45 P.M.
BXW	Singapore	2,000	9:15 P.M.
BZE	Matara, Ceylon	2,000	8:45 P.M.
BZF	Aden, British Somaliland	2,000	7:30 P.M.
BZH	Seychelles	2,000	9:45 P.M.
BZG	Mauritius	2,000	10:30 P.M.
BZI	Durban, South Africa	2,000	3:15 A.M.
VMG	Apia, Samoa	2,000	11:30 A.M.
VLA	Awanui	2,000	7:15 A.M.
VLB	Awarua, Australia	2,000	10:45 A.M.
VID	Darwin, Australia	850	6:30 P.M.
VKT	Naura, Australia	2,200	7:00 P.M.
VIP	Perth, Australia	1,500	4:30 P.M.
VJZ	Rabaul, Australia	2,900	6:00 P.M.
VIS	Sydney, Australia	2,000	3:30 P.M.

<i>Call Letters</i>	<i>Name of Station</i>	<i>Meters</i>	<i>Time</i>
VIT	Townsville, Australia	1,000	4:30 P.M.
VIF	Woodlark Isl., Australia	1,000	5:00 P.M.
UA	Nantes, France	2,400	3:30 A.M. 3:45 P.M.
FL	Paris, France	2,500	3:00 P.M.
YN	Lyons, France	5,000	8:00 A.M.

Every experimenter should have a copy of Radio Regulations, published by the Government Printing Office, Washington, D. C. Fifteen cents in cash or money order must be sent; stamps are not accepted. This book gives all the details of the International Laws, on which applicants for licenses are examined.

INDEX

A

- Abbreviations, code, 126
- Alternating current, 14
- Amperes drawn from batteries, 25
- Amplifier, construction of one-step, 118
- Amplifier, two-step, 122
- Amplifier for damped and undamped waves, 121
- Amplifiers, types of, 117
- Amplifying transformer, 118
- Antenna, acts as condenser, 17
- Antenna capacity, 64
- Antenna loop, 58
- Antenna, receiving, 57
- Antenna, transmitting, 54
- Antenna, transmitting, insulation, 56
- Anti-capacity switch, 68
- Audio frequency, 13
- Audion control set, 81
- Audion detector, action of, 72
- Audion oscillator, action of, 95

B

- Batteries, dry, connection of, 24
- B battery, 77
- Battery, C, 88

- Beat reception, 97
- Bridging condenser, 87
- Buzzer test, 51

C

- C battery, 88
- Calibration table of honeycomb coils, 63
- Capacity, antenna, 64
- Capacity of condenser, 47
- Coil, tuning, construction of, 40
- Condenser, action in, 16
- Condenser, bridging, 87
- Condenser, fixed, for receiving, 44
- Condenser, grid, 78
- Condenser, making transmitting, 28
- Condenser switch, series-parallel, 89
- Condenser to reduce sparking at key, 28
- Condenser, variable air, 47
- Condensers, tuning, with honeycomb coils, 63
- Control, audion set, 81
- Crystal detector, 42
- Crystals, detector, selection of, 43
- Current, alternating, 14
- Current, direct, 15
- Cycle, 21

- D**
- Damped oscillations, 16
 Decrement, logarithmic, 38
 Detector, action of, 20
 Detector, crystal type, 42
 Detector, crystals, selection of, 43
 De Forest, inventor of audion, 70
 Direct current, 15
 Direction finder, loop for, 59
- E**
- Electricity, speed of, 13
 Electrodes for spark gaps, 30
- F**
- Filament, audion, 72
 Fixed condenser for receiving, 44
 Foreign stations, 115, 132
 Frequency, audio, 13
 Frequency, group, 20
 Frequency, radio, 13
- G**
- Grid, audion, 72
 Grid condenser, 78
 Grid leak, 87
 Ground connections, 60
 Group frequency, 20
- H**
- Helix, 31
 Heterodyne reception, 97, 122
 High powered transmitting stations, 115, 132
 Honeycomb coils, 46
 Honeycomb coils, selection of, 48
 Honeycomb coils, calibration table for, 63
 Howling, overcoming, 87
- I**
- Induced currents, 22
 Insulation of transmitting antenna, 56
- J**
- Jeweler's time signal receiver, 82
- K**
- Key, telegraph, 27
- L**
- Lead-in insulation, 56
 Leak, grid, 87
 License, 123
 Lightning, danger from, 10
 Lightning switch, 60
 Lightning switch insulation, 57
 Lines, magnetic, 23
 Logarithmic decrement, 38
 Loop antenna, 58
 Loose coupler, honeycomb coil type, 61
 Loose coupler and audion, 87
- M**
- Magnetic lines, 23
 Modulation circuit, 107
 Modulation transformer, 111
 Modulated undamped waves, 99

N

Natural period, 12
 News reports, 130

O

Oscillating audion, 95
 Oscillating circuit, transmitting, 36
 Oscillation, 95
 Oscillation transformer, 31
 Oscillations, damped, 16
 Oscillations, undamped, 92

P

Parallel connection of batteries, 24
 Pendulum, time of swing, 11
 Period, natural, 12
 Plate, audion, 72
 Potentiometer, 80

Q

Quenched spark gap, 31

R

Radio frequency, 13
 Radio Inspectors, 124
 Radio Regulations, 133
 Range of receiver, 18
 Range of transmitter, 18
 Receiver, audion with single slide tuner, 78
 Receiver, audion with one honeycomb coil, 82
 Receiver, audion with loose coupler, 83
 Receiver, long wave, 67
 Receiver, short wave, 64

Receiver, single honeycomb coil, 49
 Receiver, two slide tuner type, 50
 Receiver, undamped wave, 94, 97, 113
 Receiving set, operation of, 51
 Regenerative circuits, 84
 Regenerative receiver, operation of, 86
 Rheostat, for audion, 77
 Rules and regulations, 123

S

Series connection of batteries, 25
 Series-parallel connection of batteries, 25
 Sliders, construction of, 40
 Socket, audion, 78
 Spark coil, construction and action of, 21
 Spark gap, construction of, 29
 Spark, quality of, for radio work, 24
 Sparking, reduction of, at key, 28
 Speed of electricity, 13
 Squealing, overcoming, 87, 122
 Stations, undamped wave, 115
 Switch, lightning, insulation of, 57
 Switch to vary transmitting condenser, 29
 Switch, anti-capacity, 68
 Switch, series-parallel condenser, 89

T

- Telegraph key, 27
 Telephone, radio, transmitter, 100
 Telephone receivers, action of, 20
 Telephone receivers, selection of, 44
 Test buzzer, 51
 Tickler coil, 84
 Tickler coil, inductance of, 86
 Tikker, 93
 Time signal receiver, 82
 Time signals, 132
 Transformer, amplifying, 118
 Transformer, modulation, 111
 Transformer, oscillation, 31
 Transformer, sending, 32
 Transmitter antennas, 54
 Transmitter, connection for spark coil, 17
 Transmitters, audion telephone and telegraph, 101
 Transmitting set, adjustment of, 34
 Transmitting instruments, arrangement of, 34
 Tuner, two slide, connections for, 50
 Tuning a transmitter, 38

- Tuning fork, 12
 Tuning, necessity for, 14

U

- Ultraudion circuit, 112
 Undamped wave generators, 95
 Undamped wave receiver, 94, 97, 113
 Undamped wave transmitters, 101
 Undamped wave transmitting stations, 115
 Undamped waves, 92

V

- Vibrator, action of, 22
 Voltage, stepping up, in spark coil, 23
 Voltage obtained from batteries, 26

W

- Weather reports, 130
 Wavelength, 13
 Wavelength, formula for, 37
 Wavelength, relation to inductance and capacity, 17
 Waves, modulated, 99
 Waves, undamped, 92

W. J. R.
...

AUG 29 1949



