

The 45rpm Phono Gazette

45 players are a hit at vintage car shows.

The other hobby I dabble in is vintage cars. I bring my 1967 Pontiac Tempest convertible to car shows and I have to admit it does not exactly stand out with all the flashy cars at the show. That all changes however when I whip out a 45 player and start playing it on the front hood. Most people then give me a thumbs up or a big smile and point to the player. The kids are the best. Many of them come over and gawk at the thing as if it is from another planet. It especially blows the kids away when I play songs by Kelly Clarkson or Avril Lavigne. These are current artists who actually put out some of their songs on 45rpm. The only way you will find them though is to search on the internet. This 45EY2 unit has been upgraded with Chris Cuff's cordless conversion. The red and white paint job is to attract attention, and it works!



Young folks who have never seen a record are intrigued by this strange device

Kutztown Swapmeet

On the east coast the radio and related item meet that is growing by leaps and bounds every year is the Delaware Valley Historic Radio Club's swapmeet at Renningers located in Kutztown, Pennsylvania. All the vendors are covered by pavilions. Occurring in May and September each year, the events have expanded to 3 days (Thursday, Friday, and Saturday). On Friday night there is 'the burning'. Radio cabinets that are absolutely unsalvageable are burned with spectacular results. On Saturday afternoon there is a sizeable auction. This time there was a huge selection of phonographs including many 45 players. There was also a vendor selling thousands of 45 rpm records. It took me 3 hours to go through them all. One interesting EP I found has 5 bands of music. I was wondering if RCA Victor was trying to squeeze 5 songs on a side, but it turned out to be a highlight disk so the songs were abbreviated, although the label gave no indication of that.



Five band EP

The 45rpm Phono Gazette

What happens when 45 rpm records are out of spec?

Here you are placing a stack of 45s on your 45 player and you're ready to sit back and enjoy the music. But after enjoying the first record, the second record does not fall during the reject cycle. You reject it again but the record refuses to fall. Unfortunately this is becoming a common problem especially when attempting to play records from the 70s, 80s or 90s. In the early days of 45s most companies followed the rules and made sure their records were made to spec. But as time has gone on, many of the newer records do not meet the original specs. The most common problem is caused when the record at the inner hole is too thick. 45 rpm records were cleverly designed so most of the label is the thickest part of the record so that the record grooves don't touch. As the label approaches the center hole, the record and label thin out so that there is a space between the records at the center hole (see picture below). If the record is out of spec at the center hole, the spindle knives will not be able to separate the record from the stack. RCA Victor's original spindle separators used gears to rotate the knives in and out during the reject cycle. If an overly thick record were on the spindle, the knives would wedge into the record and cause a stall of the turntable. Confused owners would then try to remove the records and find it next to impossible to take them off the spindle. If they tried a little too hard, they would damage the record or the separator knives. RCA Victor immediately redesigned the spindle to prevent this problem. The new design had the separators come out of the spindle with less force and they would not wedge into the bottom record. The original spindle separators were only used on the rp-168 changer in 1949 and early 1950. Later rp-168 models and all rp-190 models used the redesigned spindle separators. The correct way to free up a stall with the early design is to shut the changer off and from underneath rotate the star wheel until the record is freed. Then make sure the separators are completely recessed in the spindle before turning the machine back on.

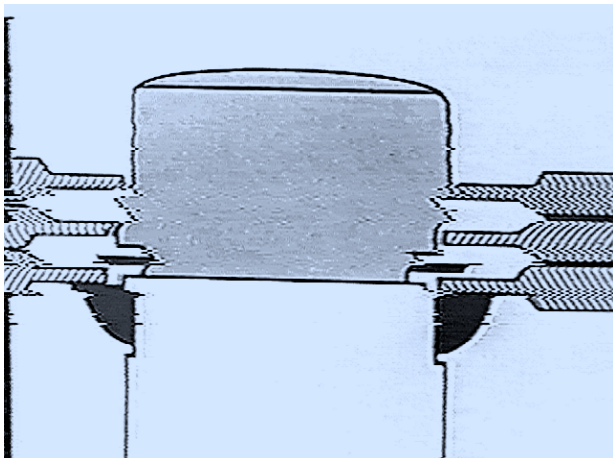

Plenty of space for separators between records when specs are met.

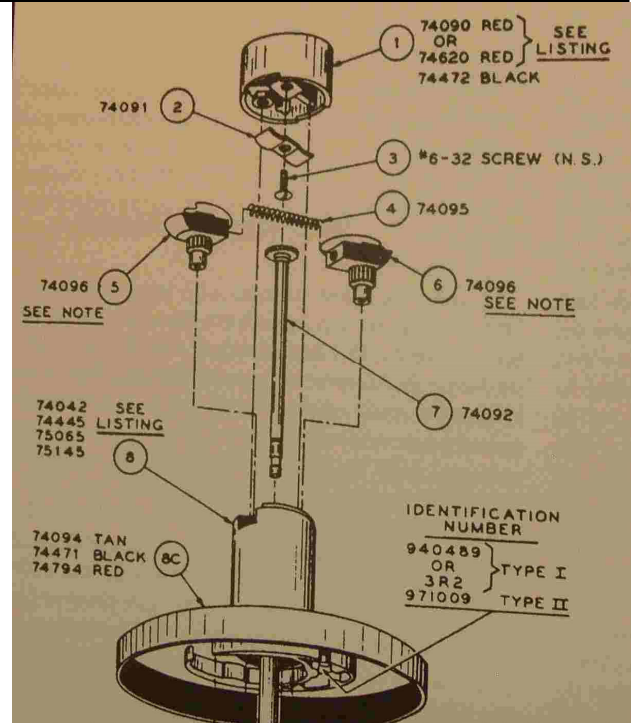

Early design with gear driven separators

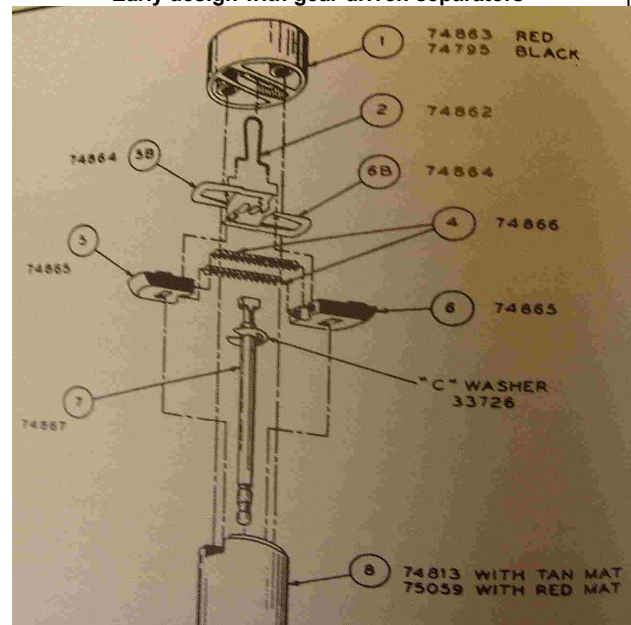

Redesigned separators which yield to overly thick records

FLASH! NOS Sonotone 1P cartridges for higher end 45 players available at Vintage Electronics. See page 4.

*The 45 rpm Phono Gazette is a quarterly publication since 1995.
\$6/\$8 for 4 issues, \$12/\$16 for 9 issues. (USA/Intl)
Send to Phil Vourtsis, 13 Cornell Place, Manalapan, NJ, 07726 or you can use Paypal (Account is pvourtsis@optonline.net, no credit cards please)*

The 45rpm Phono Gazette

Oct. 2010

Page 3

RCA Victor was in full swing with their advertising during the 2nd year of production. An advertising blitz and reduction in the price of 45 record playing attachments was credited with selling the public on '45'.

Today's fastest-selling system

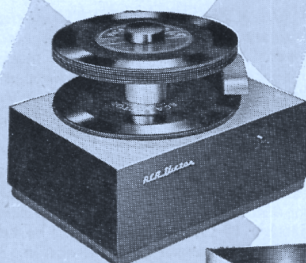

45J—The automatic record changer attachment that's selling faster than anything you've ever handled. Plays through the speaker of any radio, phonograph or television set. Beautiful, compact cabinet. Quick way to bigger record business.

Here are the "Basic 3" of many RCA Victor instruments featuring the sensational "45"!

You can offer your customers RCA Victor's "45" system in a wide variety of instruments . . . from an automatic record changer attachment to a magnificent console housing television, AM-FM, short-wave radio, 33 $\frac{1}{3}$ —78 rpm changer, and the "45" changer. That's why your profit opportunities are so much greater with "45"!

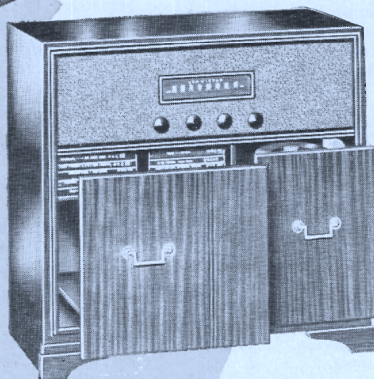

A55—Victrola radio-phonograph combination. Automatic 33 $\frac{1}{3}$ —78 rpm record changer in one drawer . . . "45" changer in another to preserve "45" sales advantages. Powerful AM radio, too. All in a smart, distinctive cabinet.

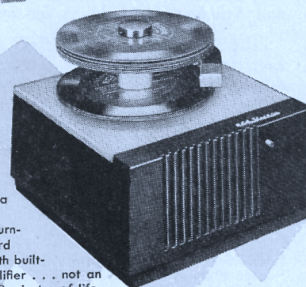

45EY—The Victrola phonograph with unprecedented, quick turn-over. Automatic record changer complete with built-in speaker and amplifier . . . not an attachment. Up to 50 minutes of life-like entertainment at touch of button. **Plus the Anniversary Album!**



ONLY RCA VICTOR HAS THE "GOLDEN THROAT"

The 45rpm Phono Gazette

Want List

Bob Becker
(201.391.2971)
7 Woodland Road
Woodcliff Lake, NJ 07677
rdbbecker@aol.com
Beige knob for 8EY4FK
Large tuning or vol knob for 9Y510
6JM25 Ding Dong Slideomatic
7HF45 Oak or Maple preferred
8EY4DJ gray plastic front with lid
Decca blk/red portable 45 player

Joe Centanni
(585.230.1539)
74 Oakbriar Ct
Penfield, NY 14526
s100x@rochester.rr.com
VM Stereo 45 player
Magnavox 45 player

Charles Cummins
(817-732-4313)
3912 Calmont Ave
Fort Worth, Texas 76107

David Cox
(937)484-3241
1407 Knight Road
Urbana, OH 43078
dcc49@yahoo.com
45 spindle for Admiral 5W12N 2-speed record player
Bakelite lid for Zenith twin seven
Outer concentric radio/phono knob for Emerson 635

Dennis D'Amico
11892 Pine Street
Los Alamitos, CA 90720-4163
lionelguy@yahoo.com

Bill Gourd
(989-832-2934)
1024 West Park Drive
Midland, Michigan 48640
In priority order:
8EY4, 7HF45 (wood case)
8HF45P (portable)
4Y511 (radio/phono)
9Y510 or 9Y511 (radio/phono)
6BY4

Hank Granse
(360-871-9014)
6751 View Dr. SE
Port Orchard, WA 98367
hgranse@wavecable.com

Bob Green
(570-366-3949)
1711 Breezy Acres Rd
Orwigsburg, PA 17961
rcgreen@schmobile.com
FOR SALE
15E Demonstrator

Doug Houston
(810-627-4141)
3441 South Hadley
Ortonville, Michigan 48462
HoustonD@tacom.army.mil

Mike Schwartz
2464 Merel Drive
Hatfield, PA 19440-2230
mikebeatles@yahoo.com
Power pack for Skipper

Ron Jeff
30 Devonshire Terrace
Flanders, NJ 07836
973-584-1007
6JY1C with green base

Bob Kolba
904.285.5483
161 Twelve Oaks Lane
Ponte Vedra Beach, FL 320082
Rkolba0211@aol.com

John Lee
1658 E. 5th St.
Ontario, CA 91764-2202
nipper45@verison.net
Can scan other character model
decal in exchange for Snow White.

John Ortale
(203-754-8346)
44 Barden Street
Waterbury, CT 06706
ortl@aol.com
Early Disney models

Tom Paruta
(716) 837-8131
43 Flower St.
Buffalo, NY
TomTMP58@aol.com
Zenith model T545 radio/phono.
Zenith twin seven (G660) or
"Dartmouth" console with twin 7

Bob Reck
(410)647-1849484
Botteford Court,
Severna Park, MD

Dan Saporito
8 - 5th Ave
Ortley Beach, NJ 08731

Doug Robinson
2609S. 800E.
Salt Lake, Utah 84106
Doug45rpm@hotmail.com

James Romano
(856-220-9588)
1101 Berlin Rd
Cherry Hill, NJ 08034
JUKEBOXJUNKIE@aol.com
Looking for RCA 15E Demonstrator

Ray Tyner
(614-475-1697)
4709 Wendler Blvd
Columbus Ohio 43230-1642
rcray45rpm@msn.com
Birch 45 player, Steelman 45 player
Chambers Williams
(817-446-0346)
9423 Marsh Creek
San Antonio, Texas 78250

Rex North
(937-368-3060)
5333 Alcony-Conover Road
Conover, Ohio 45317

Looking for spare idler and cam.

Services

Willie Bosco
707.923.3897
1588 Miller Creek Rd.
Garberville, CA 95542
williambosco@gmail.com
"Lowrider" replacement
cartridges available

Paul Childress
6632 W. Denny Ct.
Chesterfield, VA 23832
804-271-7842
pchildress@prodiqy.net

Bob Havalack
(585-458-0801)
1239 Plymouth Avenue South
Rochester, NY 14611

ebm21@frontiernet.net
Will repair/rebuild players.
Specialize in car 45 player
rebuids.
Idler and Cam rebuilding

V-M Audio Enthusiasts
(248-478-0990) eves/wkends
37530 E. Meadowhill
Northville, MI 48167
info@thevoiceofmusic.com
www.thevoiceofmusic.com
Repair parts including both
V-M and RCA 45 players.

Phil Vourtsis
(732-446-2427)
13 Cornell Place
Manalapan, NJ 07726
philvourtsis@gmail.com
Books signed by author
The Fabulous Victrola '45'
Schiffer Publishing LTD.
\$25 plus \$4 shipping

Vintage Electronics
128 Buccaneer Drive
Hattiesburg, MS 39402
601.264.4755
phonoed@aol.com
www.vintageelectronics.com
Rebuilding Service
Idlers, cams, cartridges
Flash- NOS Sonotone 1P carts for
the better sounding 45 players

West Tech Services
615 Fairground St.
Caldwell, Ohio 43724
TELE/FAX: 740-732-6056
westtechservices@yahoo.com
Rebuilding Service
Idlers, cams, cartridges

Kurt Wilmarth
(716.279.8948)
c/o Echo-Tone Music
991 Genesee Park Blvd
Rochester, NY 14619
Croonin@frontiernet.net
Repair/restore service

Retro-Tronics
Custom radio backs and phono
bottoms for 45EY2, 7EY series
www.retro-tronics.com