

# 45rpm Phono Gazette

By Phil Vourtsis

Well another year has come to a close and what better way to end it but with another phono fanatics get-together, or maybe we should call it another phonofest! During the Summer Ray Ayling was gracious enough to have us over and now Bob Becker put up with us on Dec 28<sup>th</sup>. Picture at right shows the gang with Steve Calandra on the left followed by Chuck Rownd, Dave Sica, Phil Vourtsis, and Rick Winegarten along the bottom. The top row has Ray Ayling, Nick Domenico, Tom Cawley, Bob Becker, Max Theis, and Kevin McDermott. The day was spent admiring Bob's collection, looking through loads of 45 records that were for sale and enjoying good food and stimulating conversation. Bob's house is full of interesting radios and phonographs but one in particular caught my eye. I had never come across this model Symphonic 45 player before. As the pictures show it is a portable with green vinyl covering and sports the early RP-168 record changer. Interestingly the graphics are all on a piece of heavy paper or light cardboard which is glued onto the unit. It's pretty amazing how many variations keep popping up .



Phono Fanatics posing for another group picture



Very seldom seen Symphonic record player



# 45rpm Phono Gazette



The RCA 9-EY-M3 Manual 45 Player

By Fred Rice

I have known of this player for many years and had the chance to purchase one about 20 years ago. It appears in the RCA red book series but no where else. When I actually picked it up, I was surprised to see it uses the same case as the standard 9-EY-3 with parts left out. The big mystery to me is what was the purpose and end user of this device? Although RCA published service notes on the manual model, it never appeared in Sams Photofacts or anywhere else. I have never seen any advertisement for it either. Many years ago, I discussed it with the late Doug Houston and he felt it was sold as a store record demonstrator. Was it given away to RCA executives? I still have no idea. Two grille bars are broken on the manual model but I decided to leave it alone.

Here are underside views. The manual model is designated as RP-186. I had changed the idler wheel and added some more photos showing the mechanism. The cabinet has the hole for the reject button and the mounting holes for it but never used. Same as for the top holes for arm landing and height adjustments. The turntable is special for this and the 9JYM manual attachment. The spindle itself is short and slightly tapered. The red spindle nose is unique to these two models. Even though the casting has some of the cam, the cam center is not used. piece of rubber tubing on the bottom of the tonearm shaft holds it from pulling out. Note the production code 16<sup>th</sup> week of 1949.



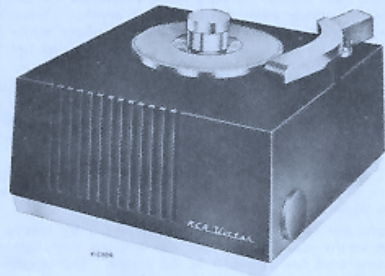

# RCA VICTOR

Manual Record Player

## MODEL 9EYM3

Chassis No. RS-132

— Mfr. No. 274 —

### SERVICE DATA

— 1949 No. 10 —

RADIO CORPORATION OF AMERICA  
RCA VICTOR DIVISION  
CAMDEN, N. J., U. S. A.

#### Specifications

##### Tube Complement

- 1. RCA 12AV6 ..... Amplifier
- 2. RCA 50C5 ..... Output
- 3. RCA 35W4 ..... Rectifier

##### Loudspeaker (92577-6W)

- Size and type ..... 4 in. P.M.
- Voice coil impedance ..... 3.2 ohms at 400 cycles

##### Dimensions (overall)

- Height, 6 $\frac{1}{4}$ "
- Width, 9 $\frac{1}{4}$ "
- Depth, 9 $\frac{5}{8}$ "

##### Weight

- ..... 9 $\frac{1}{2}$  lbs.

##### Power Supply Rating

- 115 volts, 60 cycles A.C. .... 45 watts

##### Power Output

- Undistorted ..... 1.0 watt
- Maximum ..... 1.25 watts

##### Record Player (RP 186-1)

- Turntable speed ..... 45 r.p.m.
- Record used ..... RCA 7 in. fine groove
- Record capacity ..... 1 record
- Pickup ..... Crystal (medium output)

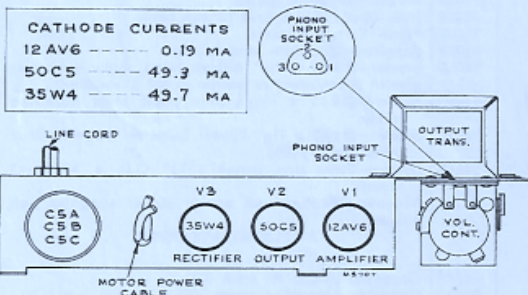

Amplifier Top View

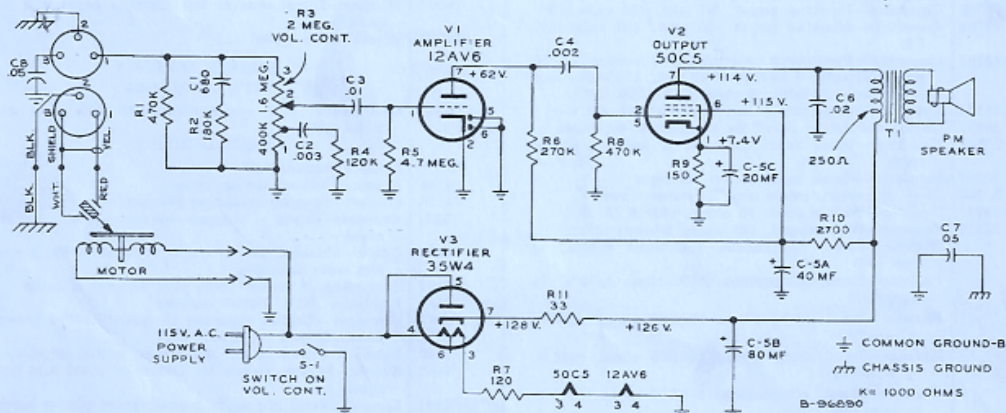

VOLTAGES MEASURED TO COMMON WIRING WITH "VOLTOHMYST" — SHOULD HOLD WITHIN  $\pm 20\%$

Schematic Diagram

Trademarks "RCA Victor," "Voltohmyst," Reg. U. S. Pat. Off.

WANTED	WANTED	SERVICES	SERVICES
<p><b>Bob Becker</b> (201.391.2971) 7 Woodland Road Woodcliff Lake, NJ 07677 <a href="mailto:rdbbecker@aol.com">rdbbecker@aol.com</a> Beige knob for 8EY4FK Large tuning or vol knob for 9Y510,6JM25 Ding Dong Slideomatic 7HF45 Oak or Maple 8EY4DJ gray plastic front Decca blk/red portable 45 player</p>	<p><b>Hank Granse</b> (360-871-9014) 6751 View Dr. SE Port Orchard, WA 98367 <a href="mailto:hgranse@wavecable.com">hgranse@wavecable.com</a></p>	<p><b>Willie Bosco</b> 707.923.3897 1588 Miller Creek Rd. Garberville, CA 95542 <a href="mailto:williamjbosco@gmail.com">williamjbosco@gmail.com</a> Cam kits available.</p>	<p><b>Vintage Electronics</b> 128 Buccaneer Drive Hattiesburg, MS 39402 601.264.4755 <a href="mailto:phonoed@aol.com">phonoed@aol.com</a> <a href="http://www.vintageelectronics.com">www.vintageelectronics.com</a> NOS cartridges &amp; needles for almost every model and brand made.</p>
<p><b>Joe Bentrovado</b> (973.361.7392) Looking for optional pwr supply for 'skipper' model</p>	<p><b>Bob Green</b> (570-366-3949) 1711 Breezy Acres Rd Orwigsburg, PA 17961 For Sale- 15E Demonstrator <a href="mailto:rcgreen@schmobile.com">rcgreen@schmobile.com</a></p>	<p><b>Tom Paruta</b> (716.264.4035) 127 Creekside Drive Amherst, NY 14228 <a href="mailto:TomTMP58@aol.com">TomTMP58@aol.com</a> Zenith Twin Seven I do 1940s thru 1960s phono restorations. Call for quotes.</p>	<p><b>V-M Audio Enthusiasts</b> (248-478-0990) eves/wkends 37530 E. Meadowhill Northville, MI 48167 <a href="mailto:info@thevoiceofmusic.com">info@thevoiceofmusic.com</a> <a href="http://www.thevoiceofmusic.com">www.thevoiceofmusic.com</a> Rebuilding Service - Idlers, cams. Repair parts including both V-M and RCA 45 players.</p>
<p><b>Charles Cummins</b> (817-732-4313) 3912 Calmont Ave Fort Worth, Texas 76107</p>	<p><b>Bob Kolba</b> 480.203.2241 8676 East Woodley Way Scottsdale, AZ 85266 <a href="mailto:Rkolba0211@aol.com">Rkolba0211@aol.com</a></p>	<p><b>Retro-Tronics</b> Custom radio backs and phono bottoms for 45EY2, 7EY series <a href="http://www.retro-tronics.com">www.retro-tronics.com</a></p>	<p><b>Phil Vourtsis</b> (732-208-4284) 2514 Bear Stand Trail Myrtle Beach, SC 29588 <a href="mailto:philvourtsis@gmail.com">philvourtsis@gmail.com</a> Books signed by author The Fabulous Victrola '45', Schiffer Publishing LTD. \$25 plus \$4 shipping</p>
<p><b>David Cox</b> (937)484-3241 1407 Knight Road Urbana, OH 43078 <a href="mailto:dcc49@yahoo.com">dcc49@yahoo.com</a> 45 spindle for Admiral 5W12N 2-speed record player, bakelite lid for Zenith twin 7 Outer concentric radio/phono knob for Emerson 635</p>	<p><b>John Lee</b> 314 East 11<sup>th</sup> St. Upland, CA 91786 <a href="mailto:Nipper45@verizon.net">Nipper45@verizon.net</a> Can scan other character model decals in exchange for Snow White</p>	<p><b>James Romano</b> Phono_restoration_company 301 Haynes Run Medford, NJ 08055 (856-220-9588) Restoration of RCA 45rpm phonos &amp; knock off models. Repair on any changer or turntable. <a href="mailto:JUKEBOXJUNKIE731@aol.com">JUKEBOXJUNKIE731@aol.com</a> Webpage: <a href="http://www.turntablefactory.com/romano.html">http://www.turntablefactory.com/romano.html</a></p>	<p><i>The 45 rpm Phono Gazette is a quarterly publication since 1995. \$7/\$9 for 4 paper issues, \$14/\$18 for 9 paper issues. (USA/Intl) Send to Phil Vourtsis, 2514 Bear Stand Trail, Myrtle Beach, SC 29588 or you can use Paypal (Account is <a href="mailto:philvourtsis@gmail.com">philvourtsis@gmail.com</a> (no credit cards please)</i></p>
<p><b>Dennis D'Amico</b> 11892 Pine Street Los Alamitos, CA 90720-4163 <a href="mailto:lionelguy@yahoo.com">lionelguy@yahoo.com</a></p>	<p><b>Paul Childress</b> (804.271.7842) 6632 W. Denny Ct. Chesterfield, VA 23832 <a href="mailto:pchildress@prodigy.net">pchildress@prodigy.net</a></p>	<p><b>Doug Robinson</b> 2609S. 800E. Salt Lake, Utah 84106 <a href="mailto:Doug45rpm@hotmail.com">Doug45rpm@hotmail.com</a> <b>WANTED: Chris Cuff to restore my Ristaucrat model 2020 player.</b></p>	<p><i>Please note! If you would like to renew your subscription with an 'online' copy there is NO CHARGE. Just send me your email address.</i></p>
<p><b>Jim Diamond</b> (661-396-7867) <a href="mailto:JimDiamond61@gmail.com">JimDiamond61@gmail.com</a> Want Spike Jones 78s Hot Lips, Holiday For Strings, Down in Jungle Town, Too Young, Chinese Mule Train. Hank Williams "Your Cheatin'Heart/Kawliga", Tommy Dorsey's "At The Codfish Ball"and Nat King Cole's "Too Young To Go Steady"</p>	<p><b>Dan Saporito</b> (732.232.2953) 1225 NW 21<sup>st</sup> ST Apt. 302 Stuart, FL 34994</p>	<p><b>Ray Tyner</b> (614-475-1697) 4709 Wendler Blvd Columbus Ohio 43230-1642 <a href="mailto:rcray45rpm@msn.com">rcray45rpm@msn.com</a> Birch 45 player, Steelman 45 player</p>	
<p><b>Bill Gourd</b> (989-832-2934) 1024 West Park Drive Midland, Michigan 48640 <u>In priority order:</u> 8EY4, 7HF45 (wood case) 8HF45P (portable) 4Y511 (radio/phono)</p>	<p><b>Martin Wolff</b> (712-525-1054) <a href="mailto:wolfmoma@g.com">wolfmoma@g.com</a> Looking for 45 spindle for 9ED31L 2-speed player. Part # 104271.</p>		