

**VTU-4CX3500A
VHF
Radial Beam
Tetrode**



The Alpha Tubes VTU-4CX3500A is a compact ceramic and metal radial beam power tetrode intended for use in VHF power amplifier applications. It features a type of internal mechanical structure which results in high rf operating efficiency. Low rf losses in this structure permit operation at full ratings to 220 MHz. The VTU-4CX3500A has a gain of over 18 dB in FM Broadcast service, and is also recommended for linear rf power amplifier service and VHF-TV linear amplifier service. The anode is rated for 3500 watts of dissipation with forced-air cooling.

Electrical Characteristics¹

Filament.....	Mesh type, Thoriated Tungsten
Voltage.....	5.0 ± 0.25 Volts
Current at 5.0 Volts.....	90 Amperes
Amplification Factor, average, Grid to Screen.....	4.5
Direct Interelectrode Capacitances ²	
Grounded Cathode	
Cin.....	111 pf
Cout.....	12 pf
Cgp.....	0.5 pf
Grounded Grid	
Cin.....	58.5 pf
Cout.....	10 pf
Cpk.....	0.4 pf
Maximum Frequency for Full Ratings (CW).....	220 MHz

1. Characteristics and operating values are based on performance tests. These figures may change without notice as the result of additional data or product refinement.
2. Capacitance values are for a cold tube as measured in a special shielded fixture in accordance with EIA Standard RS-191.

Revised 1 July 2013



ALPHA TUBES

634 SOUTH SUNSET ST. * LONGMONT * COLORADO 80501
(303) 473-9232 * FAX: (303) 473-9660

Mechanical Characteristics

Maximum Overall Dimensions		
Length.....	7.25 (18.42)	Inch (mm)
Diameter.....	4.94 (12.55)	Inch (mm)
Net Weight (approx.)	5.5 (2.5)	Lbs (kg)
Operating Position	Axis Vertical, Base Up or Down	
Cooling	Forced Air	
Maximum Operating Temperature	250	°C
Base	Special, Coaxial	

Maximum Ratings and Typical Operation

**Radio Frequency Power Amplifier
Class C Telegraphy of FM (Key-down Conditions)**

Absolute Maximum Ratings

DC Plate Voltage	6000	Volts
DC Screen Voltage.....	1500	Volts
DC Grid Voltage.....	-500	Volts
Plate Dissipation.....	3500	Watts
Screen Dissipation.....	165	Watts
Grid Dissipation	50	Watts

Typical Operation (Frequencies to 30 MHz)

Plate Voltage	5000	5000	Volts
Screen Voltage	500	500	Volts
Grid Voltage.....	-200	-250	Volts
Plate Current	1.32	0.80	Amperes
Screen Current (approx.).....	75	43	mA
Grid Current (approx.)	59	21	mA
Peak rf Grid Voltage (approx.).....	335	290	v
Calculated Driving Power	25	7	Watts
Plate Dissipation (approx.)	1320	640	Watts
Plate Output Power	5280	3360	Watts
Load Impedance.....	1700	2700	Ohms

**Radio Frequency Power Amplifier
FM Broadcast Service**

Absolute Maximum Ratings

DC Plate Voltage	6000	Volts
DC Screen Voltage.....	1500	Volts
DC Grid Voltage.....	-500	Volts
DC Plate Current.....	2.0	Amperes
Plate Dissipation.....	3500	Watts
Screen Dissipation.....	165	Watts
Grid Dissipation	50	Watts

Measured Data at 100.5 MHz

Plate Voltage	4000	4300	Volts
Plate Current	1.5	1.9	Amperes
Screen Voltage	500	700	Volts
Screen Current (approx.).....	140	123	mA
Grid Voltage.....	-300	-400	Volts
Grid Current (approx.)	84	63	mA
Useful Power Output (approx., delivered to load).....	3838	5531	Watts
Efficiency (approx.).....	64	68	%
Driving Power (approx.).....	56	66	Watts
Power Gain (approx.)	18.4	19.2	dB

Typical Operation values are obtained by measurement or by calculation from published characteristic curves. To obtain the specified plate current at the specified bias, screen, and plate voltages, adjustment of the rf grid voltage is assumed. If this procedure is followed, there will be little variation in output power when the tube is replaced, even though there may be some variation in grid currents. The grid and screen currents which occur when the desired plate current is obtained are incidental and vary from tube to tube. These current variations cause no performance degradation providing the circuit maintains the correct voltage in the presence of the current variations. If grid bias is obtained principally by means of a grid resistor, the resistor must be adjusted to produce the required bias voltage when the correct rf grid voltage is applied.

Application Considerations

Mechanical

Mounting

The VTU-4CX3500A must be mounted with its axis vertical, base up or down at the convenience of the circuit designer.

Cooling

At full rated anode dissipation, at sea level and with cooling air at 50 °C maximum, for frequencies below 110 MHz, and with the tube mounted in a suitable socket and chimney, a minimum of 241 CFM of air must be passed through the socket and the tube anode cooling fins. Air flow should be in the base to anode direction. The pressure drop across the tube at this air flow rate will be approximately 1.87 inches of water.

The blower selected in a given application must be capable of supplying the desired air flow at a back pressure equal to that shown, plus any drop encountered in ducts and filters.

Air flow must be applied before or simultaneously with the application of power, including the tube filament, and may be removed simultaneously with the filament voltage. An air interlock system should be incorporated in the design to automatically remove all voltages from the tube in case of even partial failure of the tube cooling air. It is considered good engineering practice to supply more than the minimum required cooling air, to allow for variables such as dirty air filters, rf seal heating, and the fact that the anode cooling fins may not be clean if the tube has been in service for some time.

Electrical**Absolute Maximum Ratings**

The values shown for each type of service are based on the "absolute system" and are not to be exceeded under any service conditions. These ratings are eliminating values outside which the serviceability of the tube may be impaired. In order not to exceed absolute ratings the equipment designer has the responsibility of determining an average design value for each rating below the absolute value of that rating by a safety factor so that the absolute values will never be exceeded under any usual conditions of supply variation in the equipment itself. It does not necessarily follow that combinations of absolute maximum ratings can be attained simultaneously.

Filament Operation

At rated (nominal) filament voltage the peak emission capability of the tube is many times that needed for communication service. A reduction in filament voltage will lower the filament temperature, which will substantially increase life expectancy. The correct value of filament voltage should be determined for the particular application. It is recommended the tube be operated at full nominal voltage for an initial stabilization period of 100 to 200 hours before any action is taken to operate at reduced voltage. The voltage should gradually be reduced until there is a slight degradation in performance (such as power output or distortion). The filament voltage should then be increased a few tenths of a volt above the value where performance degradation was noted. The operating point should be rechecked every 24 hours. Filament voltage should be closely regulated when voltage is to be reduced below nominal in this manner, to avoid any adverse influence by normal line voltage variations.

Filament voltage should be measured at the tube base or socket using an accurate rms responding meter. Periodically the procedure outlined above for reduction should be repeated, with the voltage reset as required, to assure best life.

Grid Operation

The maximum control grid dissipation is 50 watts, determined approximately by the product of the dc grid current and the peak positive grid voltage.

Screen Operation

The maximum screen grid dissipation is 165 watts. With no ac applied to the screen grid, dissipation is simply the product of the dc screen voltage and the dc screen current. With screen modulation, dissipation is dependant on rms screen voltage and rms screen current. Plate voltage, plate loading, or bias voltage must never be removed while filament and screen voltages are present, since screen dissipation ratings will be exceeded. A protective spark-gap device should be connected between the screen grid and the cathode to guard against excessive voltage.

Screen Current

The screen current may reverse under certain conditions and produce negative indications in the screen current meter. This is a normal characteristic of most tetrodes. The screen power supply should be designed with this characteristic in mind, so that the correct operating voltage will be maintained on the screen under all conditions. A current path from the screen to cathode must be provided by a bleeder resistor or a shunt regulator connected between screen and cathode and arranged to pass approximately 10% of the average screen current per connected tube. A series regulated power supply can be used only when an adequate bleeder resistor is provided.

Fault Protection

In addition to the normal plate over-current interlock, screen current interlock, and air flow interlock, the tube must be protected from internal damage caused by an internal plate arc which may occur at high plate

voltage. A protective resistance should always be connected in series with each tube anode, to absorb power supply stored energy if an internal arc should occur.

High Voltage

Normal operating voltages used with this tube are deadly, and the equipment must be designed properly and operating precautions must be followed. Design all equipment so that no one can come into contact with high voltages. All equipment must include safety enclosures for high voltage circuits and terminals, with interlock switches to open primary circuits of the power supply and to discharge high-voltage capacitors whenever access doors are opened. Interlock switches must not be bypassed or "cheated" to allow operation with access doors open. Always remember that HIGH VOLTAGE CAN KILL.

Radio Frequency Radiation

Avoid exposure to strong rf fields even at relatively low frequency. Absorption of rf energy by human tissue is dependant on frequency. Under 300 MHz most of the energy is will pass completely through the human body with little attenuation or heating effect. Public health agencies are concerned with the hazard even at these frequencies. OSHA (Occupational Safety and Health Administration) recommends that prolonged exposure to rf radiation should be limited to 10 milliwatts per square centimeter.

Interelectrode Capacitance

The actual internal interelectrode capacitance of a tube is influenced by many variables in most applications, such as stray capacitance to the chassis, capacitance between tube terminals, and wiring effects. To control the actual capacitance values within the tube, as the key component involved, the industry and Military Services use a standard test procedure as described in Electronic Industries Association Standard RS-191. This requires the use of specially constructed test fixtures which effectively shield all external tube leads from each other and eliminates any capacitance reading to "ground". The test is performed on a cold tube. Other factors being equal, controlling internal tube capacitance in this way normally assures good interchangeability of tubes over a period of time. The capacitance values shown here are taken in accordance with Standard RS-191. The equipment designer is therefore cautioned to make allowances for the actual capacitance values which exist in any normal application. Measurements should be taken with the socket and mounting which represent approximate final layout if capacitance values are highly significant in the design.

Operating Hazards

Proper use and safe operating practices with respect to power tubes are the responsibility of equipment manufactures and users of such tubes. All persons who work with or are exposed to power tubes or equipment which utilizes such tubes must take precautions to protect themselves against possible serious bodily injury. Do not be careless around such products.

The operation of this tube may involve the following hazards, any one of which, in the absence of safe operating practices and precautions, could result in serious harm to personnel:

1. **High Voltage** - Normal operating voltages can be deadly.
Always remember that high voltage can kill.
2. **RF Radiation** - Exposure to strong rf fields should be avoided, even at relatively low frequencies. The dangers of rf radiation are more severe at UHF and microwave frequencies and can cause serious bodily and eye injuries. Cardiac pacemakers may be effected.
3. **Hot Surfaces** - Surfaces of air cooled radiators and other parts of tubes can reach temperatures of several hundred degrees C and cause serious burns if touched for several minutes after all power is removed.

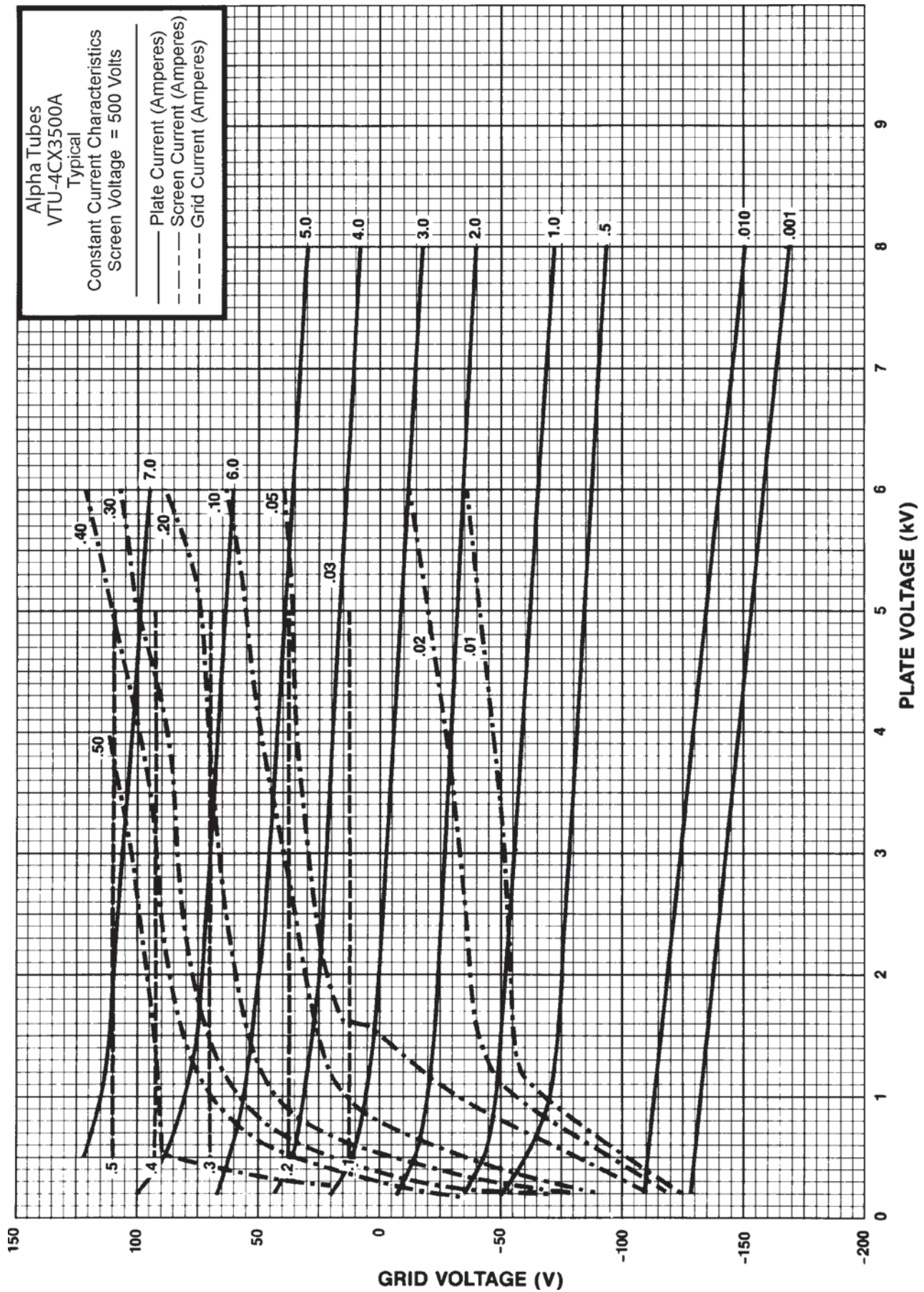

VTU-4CX3500A VHF Radial Beam Tetrode

Dimensional Data

Dim.	Inches		Millimeter	
	Min.	Max.	Min.	Max.
A	4.812	4.938	122.22	125.43
B	0.855	0.895	21.72	22.73
C	0.600	0.760	15.24	19.30
D	1.896	1.936	48.16	49.17
E	3.133	3.173	79.58	80.59
F	3.792	3.832	96.32	97.33
G	3.980	4.020	101.09	102.11
H	0.188	---	4.78	---
J	0.188	---	4.78	---
K	0.188	---	4.78	---
M	3.474	3.848	85.11	94.28
N	1.359	1.733	33.30	42.46
P	6.931	7.181	169.81	175.93
S	2.359	2.733	57.80	66.96
T	0.375	---	9.53	---

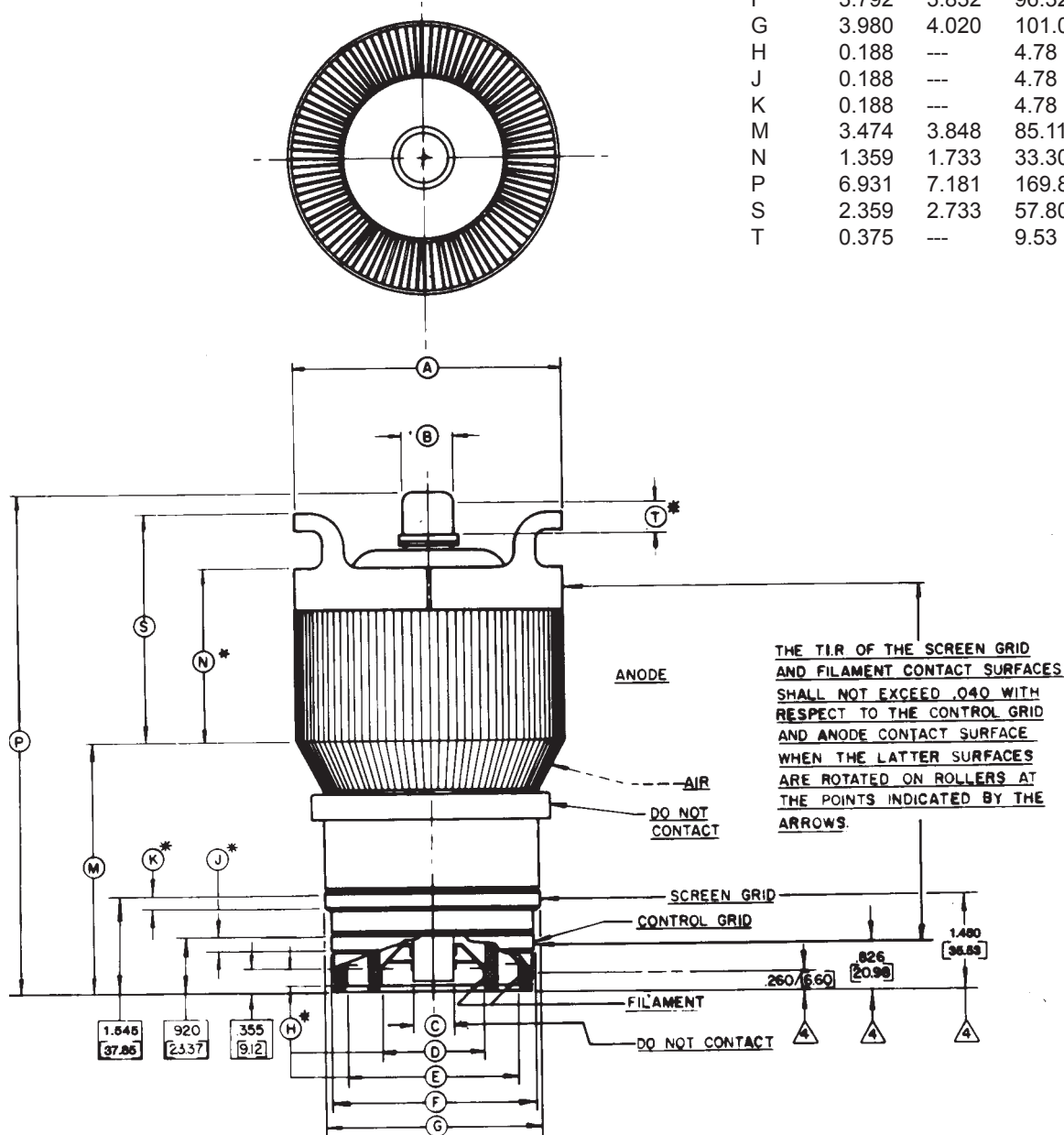

Notes

- 1 Ref. dimensions are for info only and are not required for inspection purposes.
- 2 Dimensions in [] are millimeters.
- 3 (*) Contact surfaces.
- 4 Optimal filament and grid connector heights for socket design purposes.