

TUNG-SOL

CATHODE RAY

THE 21EP4, 21EP4A AND 21EP4B ARE DIRECT-VIEW PICTURE TUBES DESIGNED FOR USE IN TELEVISION APPLICATIONS. THE 21EP4A AND 21EP4B HAVE EXTERNAL CONDUCTIVE COATINGS WITH THE 21EP4B ALSO HAVING AN ALUMINIZED SCREEN. IN ALL OTHER RESPECTS THESE TUBES ARE IDENTICAL. THEIR COMMON FEATURES INCLUDE:

UNIPOTENTIAL CATHODE	GREY FILTER FACEPLATE
CYLINDRICAL FACEPLATE	MAGNETIC FOCUS & DEFLECTION
EXTERNAL SINGLE FIELD ION TRAP	19 1/8" X 13 7/8" RASTER SIZE

ELECTRICAL DATA

FOCUSING METHOD		MAGNETIC
DEFLECTING METHOD		MAGNETIC
DEFLECTION ANGLE (APPROX.):		
HORIZONTAL	65	DEGREES
DIAGONAL	70	DEGREES
DIRECT INTERELECTRODE CAPACITANCES (APPROX.):		
CATHODE TO ALL OTHER ELECTRODES	5	$\mu\mu f$
GRID #1 TO ALL OTHER ELECTRODES	6	$\mu\mu f$
EXTERNAL CONDUCTIVE COATING TO ANODE (MAX.)	21EP4A & 21EP4B 750	$\mu\mu f$
EXTERNAL CONDUCTIVE COATING TO ANODE (MIN.)	500	$\mu\mu f$

OPTICAL DATA

PHOSPHOR NUMBER	SULFIDE TYPE	NO. 4
FLUORESCENT COLOR		WHITE
PHOSPHORESCENT COLOR		WHITE
PERSISTENCE		MEDIUM
FACEPLATE LIGHT TRANSMISSION AT CENTER (APPROX.)	66	PERCENT

MECHANICAL DATA

OVERALL LENGTH	$23 \pm 3/8$	INCHES
GREATEST DIMENSIONS OF BULB:		
DIAGONAL	$21 \frac{1}{4} \pm 3/16$	INCHES
WIDTH	$20 \frac{1}{4} \pm 3/16$	INCHES
HEIGHT	$15 \frac{9}{16} \pm 3/16$	INCHES
MINIMUM USEFUL SCREEN DIMENSIONS:		
WIDTH	$19 \frac{1}{8}$	INCHES
HEIGHT	$13 \frac{7}{8}$	INCHES
BULB CONTACT	RECESSED SMALL CAVITY CAP	J4-21
BASE	SMALL SHELL DUODECAL 5 PIN	B5-57
BASING	21EP4A & 21EP4B —12N	21EP4 12D
BULB CONTACT ALIGNMENT		
J4-21 CONTACT ALIGNS WITH PIN POSITION #6 ± 30 DEGREES		

PIN CONNECTIONS

- PIN 1 — HEATER
- PIN 2 — GRID NO. 1
- PIN 10 — GRID NO. 2
- PIN 11 — CATHODE
- PIN 12 — HEATER
- ANODE CAP: GRID NO. 3

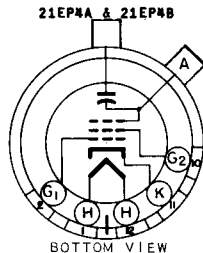
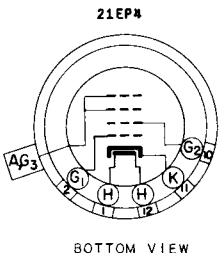

CONTINUED ON FOLLOWING PAGE

PRINTED IN U. S. A.

TUNG-SOL

CONTINUED FROM PRECEDING PAGE

RATINGS

DESIGN CENTER VALUES

HEATER VOLTAGE	6.3	VOLTS
HEATER CURRENT	0.6	AMP.
MAXIMUM DC ANODE, GRID #3 VOLTAGE ^A	18 000	VOLTS
MAXIMUM DC GRID #2 VOLTAGE	500	VOLTS
MAXIMUM GRID #1 VOLTAGE:		
DC NEGATIVE-BIAS VALUE	125	VOLTS
DC POSITIVE-BIAS VALUE	0	VOLTS
POSITIVE-PEAK VALUE	2	VOLTS
MAXIMUM DC PEAK HEATER-CATHODE VOLTAGE:		
HEATER NEGATIVE WITH RESPECT TO CATHODE		
DURING WARM-UP PERIOD NOT TO EXCEED 15 SECONDS	410	VOLTS
AFTER EQUIPMENT WARM-UP PERIOD	150	VOLTS
HEATER POSITIVE WITH RESPECT TO CATHODE	150	VOLTS

^A BECAUSE THE RATING OF THIS TUBE PERMITS ANODE VOLTAGES AS HIGH AS 19.8KV, SHIELDING OF X-RAY RADIATION FROM THE TUBE MAY BE NECESSARY. THIS PRECAUTION SHOULD BE OBSERVED WHEN THE ANODE IS OPERATED IN EXCESS OF 16KV.

TYPICAL OPERATING CONDITIONS AND CHARACTERISTICS

DC ANODE, GRID #3 VOLTAGE	12 000	VOLTS
DC GRID #2 VOLTAGE	300	VOLTS
DC GRID #1 VOLTAGE ^B	-33 TO -77	VOLTS
DC FOCUSING COIL CURRENT (APPROX.) ^C	95 ± 20%	MA.
DC ION TRAP CURRENT STANDARD COIL #111 (APPROX.)	75 ± 50%	MA.
ION TRAP FIELD INTENSITY (RATED STRENGTH)	35	GAUSSSES

^B VISUAL EXTINCTION OF UNDEFLECTED FOCUSED SPOT.

^C FOR STANDARD FOCUS COIL #109, OR EQUIVALENT, WITH THE COMBINED GRID #1 BIAS VOLTAGE AND VIDEO SIGNAL VOLTAGE ADJUSTED TO PRODUCE A HIGHLIGHT BRIGHTNESS OF 20 FOOT LAMBERTS ON A 13 7/8" BY 19 1/8" PICTURE SIZE. DISTANCE FROM REFERENCE LINE TO CENTER OF AIR GAP ON FOCUS COIL SHALL BE 3.0 INCHES.

CIRCUIT VALUES

MAXIMUM GRID #1 CIRCUIT RESISTANCE	1.5	MEG OHMS
------------------------------------	-----	----------

TUNG-SOL

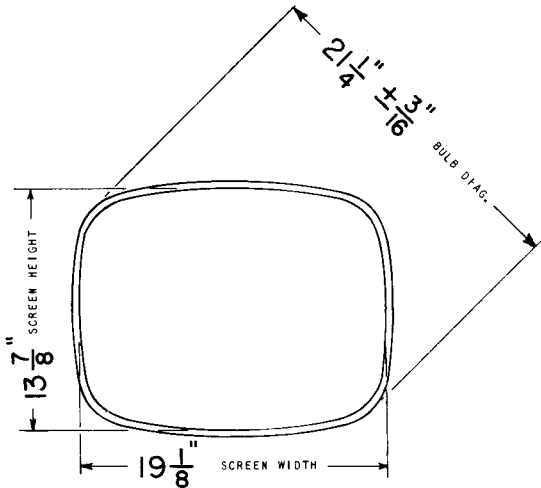
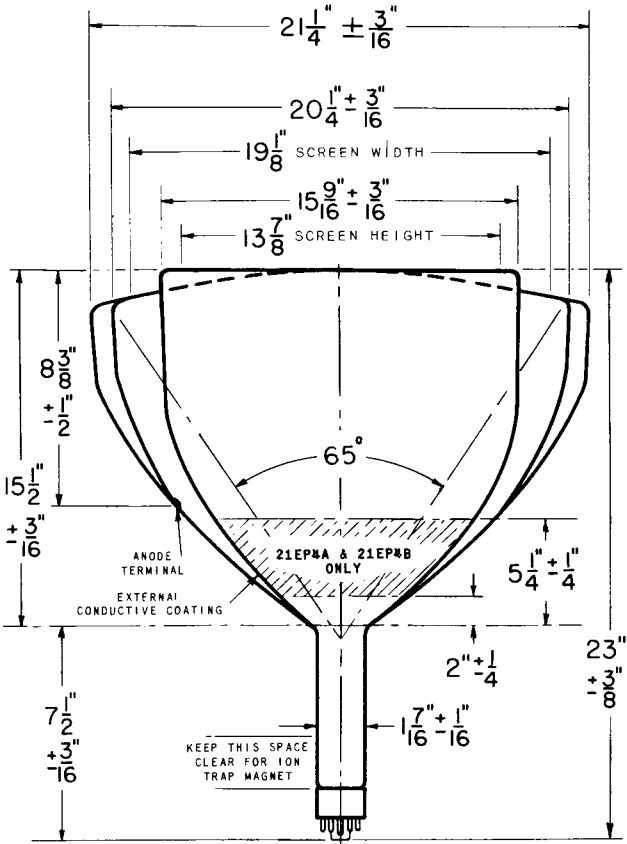

PRINTED IN U. S. A.