



TYPE 6J7GT

HYTRON BANTAM

GENERAL DESCRIPTION

Application: The Hytron 6J7-GT is a cathode type pentode designed primarily for service as a biased detector and in such use is capable of comparatively high gain. It may also be employed as a high gain amplifier of radio or audio frequency signals. An internal shield is connected to the No. 1 base pin.

The Hytron 6J7GT is a glass tube equipped with a small octal base and may be used interchangeably with the Hytron 6J7G glass tube.

Physical Characteristics: Bulb T-9C

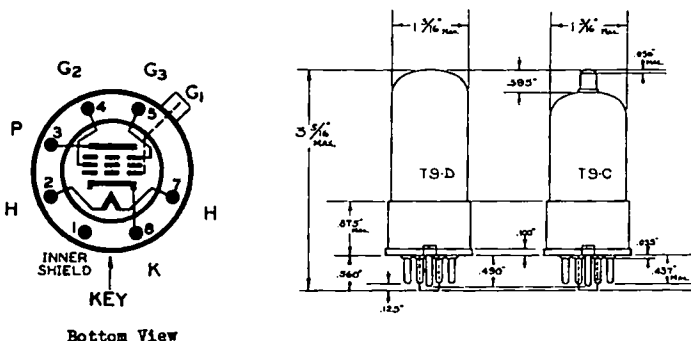

RATING AND CHARACTERISTICS

Heater:
Voltage 6.3 Volts AC or DC
Current 0.3 Ampere
Note: Voltage between heater and cathode should be kept at a minimum if direct connection is not possible.

AMPLIFIER OPERATION (CLASS A)

Plate Voltage	100	250	Max.	Volts
Screen Voltage	100	**100		Volts
***Grid Voltage	-3	-3		Volts
Suppressor	Connected to cathode at socket.			
Plate Current	2.0	2.0		Milliamperes
Screen Current	0.5	0.5		Milliamperes
Plate Resistance	1.0	1.5	Min.	Megohm
Amplification Factor	1185	1500	Min.	
Mutual Conductance	1185	1225		Micromhos
*Grid Voltage	-7	-7		Approx. Volts

* Voltage for Cathode Current Cut-Off.
** Screen Voltage = 125 Max. Volts.
*** Grid Circuit Resistance must not exceed 1.0 Megohm.

BIASED DETECTOR OPERATION

*Plate Supply Voltage	250	250	250	250	Volts
Screen Voltage	50	33	100	100	Volts
Grid Voltage	-2	-1.7	-3.9	-4.3	Volts
Cathode Resistor	3000	8000	4000	10,000	Ohms
Suppressor	Connected to Cathode at Socket.				
Cathode Current (Zero Signal)	0.65	0.21	0.97	0.43	Milliamperes
Plate Resistor	0.25	0.50	0.25	0.50	Megohm
Blocking Condenser	0.03	0.03	0.03	0.03	µf.
Grid Resistor of Following Tube	0.25	0.25	0.25	0.25	Megohm
**RMS RF Signal	1.18	1.21	1.38	1.37	Volts

* Effective plate voltage will be this value minus the voltage drop in the plate resistor.
** 20% Modulation. Output voltage for each set of conditions 17 peak audio volts at grid of following tube.

Direct Interelectrode Capacitances:

°Grid No. 1 to Plate	0.007	µµf. Max.
Grid No. 1 to all other electrodes	4.1	µµf.
Plate to all other electrodes	12.0	µµf.
°With shield can.		

Note: For characteristic curves refer to the type 6J7G



TYPE 6J7-GT

<u>ITEM</u>	<u>AS REGISTERED</u>	<u>AS PROPOSED</u>	
<u>Under AMPLIFIER OPERATION (Class A)</u>			
Rating System	none shown	Design-Center	
<u>Maximum Ratings:</u>			
Plate Voltage	250 max.	300 max.	volts
Suppressor	none	Connect to cathode at socket	
Screen Voltage	125 max.	See J5-C4-2	volts
Screen-Supply Voltage	none	300 max.	volts
Plate Dissipation	none	0.75 max.	watt
<u>Screen Input:</u>			
For screen voltages up to 150 volts	none	0.1 max.	watt
For screen voltages between 150 and 300 volts	none	See J5-C4-2	
<u>Grid Voltage:</u>			
Positive bias value	none	0 max.	volts
<u>Peak Heater-Cathode Voltage:</u>			
Heater negative with respect to cathode	-	90 max.	volts
Heater positive with respect to cathode	-	90 max.	volts
<u>Under Direct Interelectrode Capacitances:</u>			
Grid No.1 to Plate ^o	0.007 max.	delete	$\mu\mu\text{f}$
Grid No.1 to Plate*	-	0.005 max.	$\mu\mu\text{f}$
Grid No.1 to all other electrodes	4.1	delete	$\mu\mu\text{f}$
Grid No.1 to cathode, heater, grid No.2, grid No.3 internal shield & base sleeve*	none	4.6	$\mu\mu\text{f}$
Plate to all other electrodes	12.0	delete	$\mu\mu\text{f}$
Plate to cathode, heater, grid No.2, grid No.3 internal shield & base sleeve*	none	12	$\mu\mu\text{f}$

^o With shield can

* With external shield JEDEC No.308 connected to cathode.